

10 kW, 15 ϕ Axial flux pancake generator for 2-blade Wind Turbine

Abstract

A 10kW permanent magnet electric generator has been built and tested for use with a high tsr 5m blade diameter wind turbine. The system was configured for 15 phase, 15 coils and 16 poles. Each coil is individually rectified to dc, reducing cogging and allowing better control over the output voltage. Total cost of the generator was AU\$873 and was constructed with typical “home-workshop” tools.

Keywords: Wind power, Permanent Magnet Generator, 10kw wind turbine

LIST OF FIGURES

<u>Figure</u>		<u>Page</u>
1	Rear half of the generator rotor	2
2	Front half of generator rotor	2
3	Generator stator	3
4	Front half of generator rotor with magnets attached	3
5	Assembled generator	4
6	Testing the assembled generator	5
7	Measured RMS Voltage under no load, internal resistance is 2.5 Ohms	6
8	Measured voltage into matched load (2.5 Ohm)	6
9	Measured RMS power generated for all 15 coils into a matched load	7

1. Construction of the Permanent Magnet Generator



Figure 1. Rear half of the generator rotor

The rear plate (rotor) is mounted on a trailer axial bearing, it holds the first set of 16 neodymium magnets.



Figure 2. Front half of generator rotor

The front plate holds the second set of 16 neodymium magnets, this plate is bolted to the rear half of the generator rotor completing the magnetic circuit.



Figure 3. Generator stator

15 independent coils have been fixed into the stator using 24 hour epoxy resin. The coils have a thickness of 12 mm, they measure 2.5 Ohms each and are wound using 0.6mm diameter wire. This stator will be remade out of fibreglass, and the holes in the centre of the coils will be reduced to increase the power output. Epoxy and aluminium should be avoided in the generator due the fact that epoxy softens in as little as 60°C and aluminium has no fatigue limit, any infinitesimally small stresses will eventually cause failure.



Figure 4. Front half of generator rotor with magnets attached

The neodymium magnets grade N38, 2" x 1" x 0.5" magnetised through thickness fit into the slots of the front and rear plates. 32 holes have been drilled into both plates to help cooling of the coils.

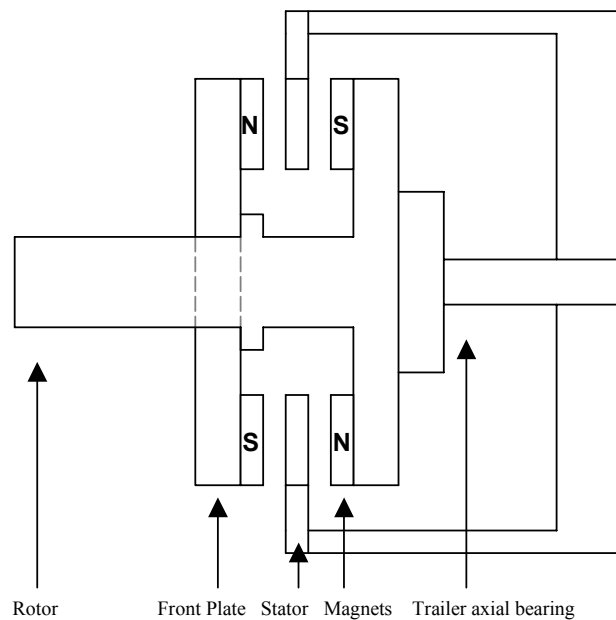

Figure 5. Assembled generator

The generator was assembled with the stator coils sandwiched between the two sets of magnets, 2mm of clearance was given between coils and magnets. Care was taken assembling as the magnetic force acting on the 32 magnets can be up to 640Kg! The generator spins freely until current flows, this is due to no iron being in the stator and the absence of cogging greatly helps starting in very low wind.

2. Total cost of the Permanent Magnet Generator

System cost (AUD)

Magnets \$500
2000m 0.6mm magnet wire \$88
2 trailer axles \$60
Steel \$50
Primer and enamel paint \$70
Welding rods \$20
Metal cutting discs \$40
Connector strips \$25
Bolts and nuts \$20

Total cost \$873

3. Testing the Permanent Magnet Generator



Figure 6. Testing the assembled generator

The generator was tested by attaching the drill to the generator, the speed of the drill and generator was controlled by an auto-transformer. Only one of the coils was put under load, the power produced by the coil was multiplied by 15 to get the total power of the generator. Voltage and frequency was measured on a oscilloscope, generator speed, open circuit voltage, and voltage under load (2.5 Ohms) was measured. Speeds above 500RPM generated considerable heat and requires cooling.

4. Measured results of the Permanent Magnet Generator

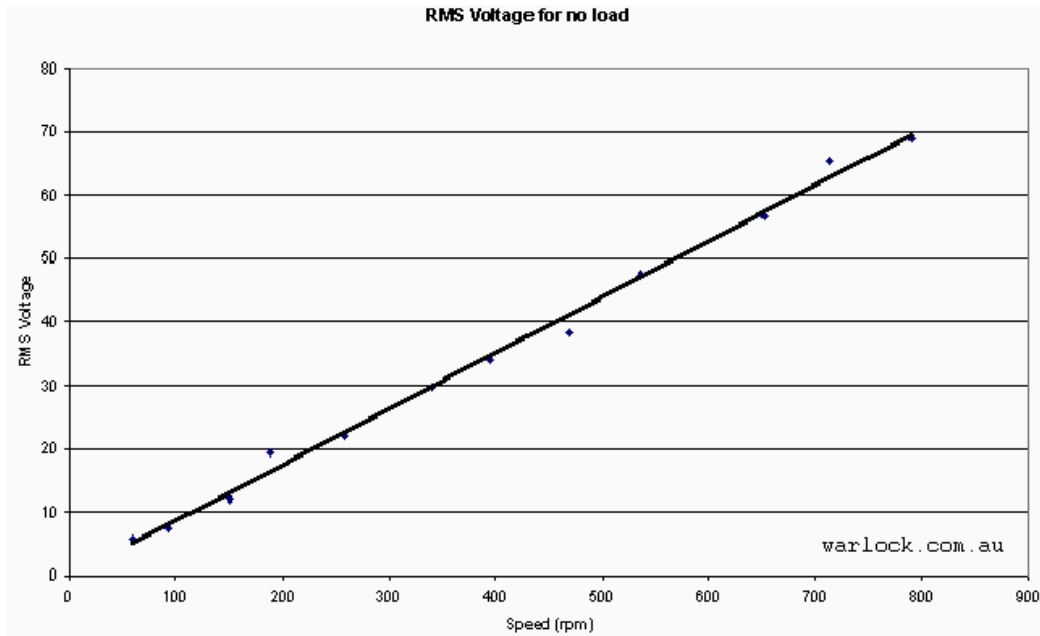

Figure 7. Measured RMS Voltage under no load, internal resistance is 2.5 Ohms

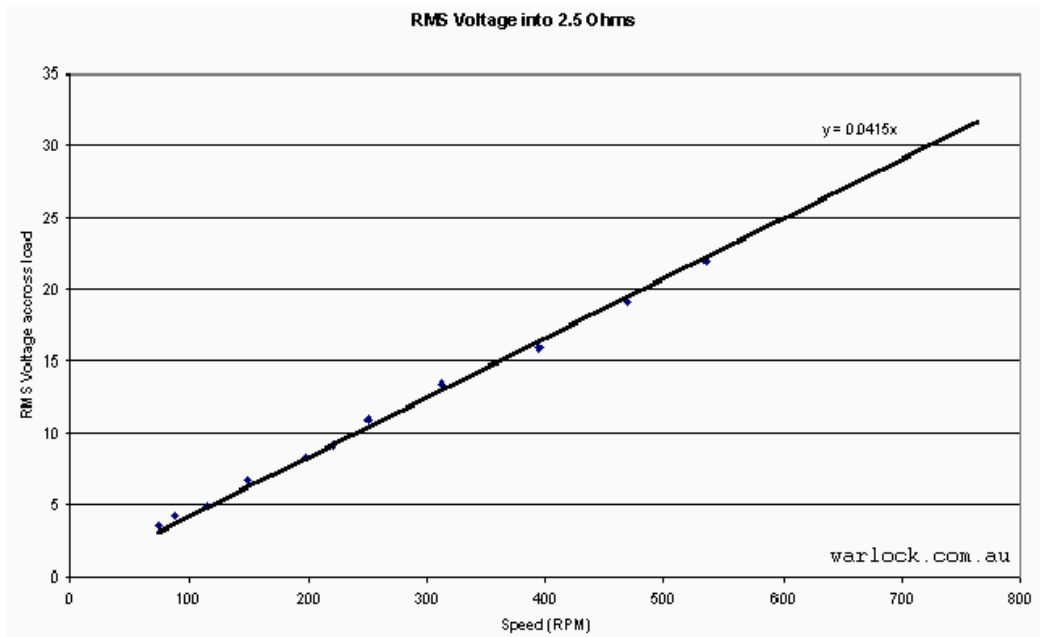

Figure 8. Measured voltage into matched load (2.5 Ohm)

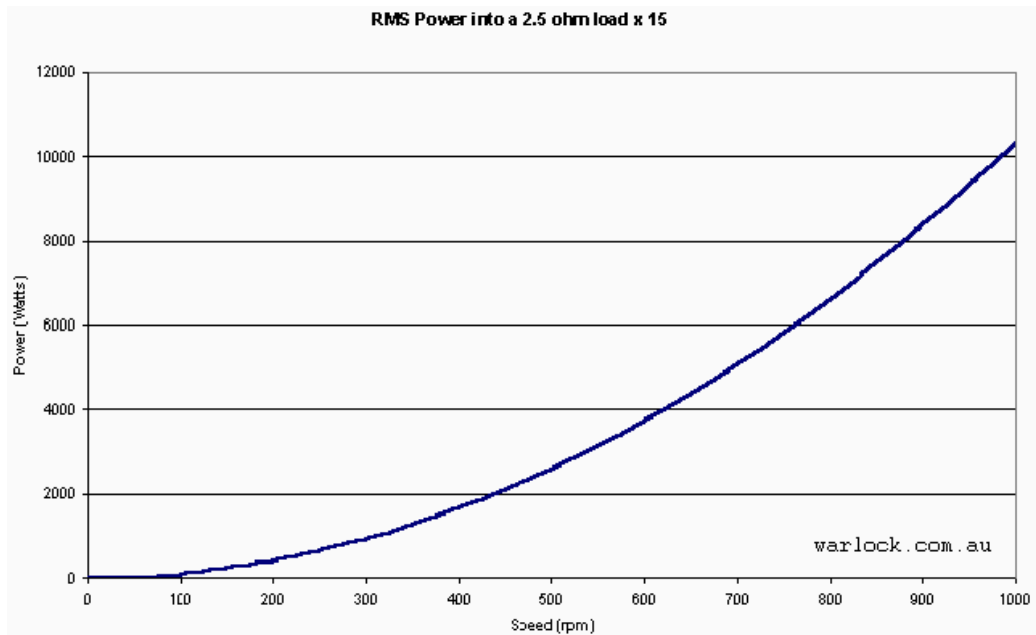

Figure 9. Measured RMS power generated for all 15 coils into a matched load
 $P = 15 \times (V^2 / R)$

4. Equipment used

Arc welder
Angle grinder
Drill
Hacksaw
Oscilloscope
Auto-transformer

5. Conclusion

A generator capable of generating up to 10kW built using cheap readily obtainable parts for a total cost of **\$873**, this compares favourably as an inexpensive alternative to the commercial generators.