

# A Wood Roller Grain Mill

*Copyright © 1995 by Dennis Cabell*

---

## Legal Stuff

This document and the wood roller grain mill design are copyrighted by the author. You may freely copy and distribute this document via a non commercial media provided that it is distributed unmodified and in its entirety, including this notice. The author reserves all rights to the wood roller grain mill design. The author grants permission to build the wood roller grain mill for non-commercial personal use only.

## Introduction

I have constructed a grain mill that uses a wood roller. I began this endeavor because I have a fixed budget for beer related items and the more I spend on equipment, the less I get to brew. I also save money because I can now buy grain in bulk at a lower price per pound. Total cost for this mill was about \$15 US. I had the wood sitting in my shop as scraps and only needed to purchase a few special pieces of hardware and some epoxy.

Although I spent very little money to build the mill, it did require quite a bit of time. I did not mind this because it is a hobby. Just decide for yourself if it makes sense to spend the time to make a mill when very good mills (better than you can make at home) are available for \$100 - \$150 US. Also, if you are a novice wood worker, these instructions may not be detailed enough.

I would like to thank the Home-Brew Digest and C.D. Pritchard. The discussion on the digest about which mill was best and crush quality with skewed rollers helped me decide on a design. I was also inspired by C.D. Pritchard's concrete roller mill and exchanged e-mail with him concerning the construction of my wooden roller.

## Overview

This is a one-roller mill. I chose the one roller design for simplicity. The roller crushes the grain against a crush plate. It was easier to construct gap adjustment with a crush plate than to design a two roller system with one adjustable roller. The crush plate is thick hard wood with a brass plate epoxied to the surface where the grain is crushed. The brass provides a smooth surface so that the husks are not torn too badly as they are drawn across the crush plate. The hopper holds 6 - 7 pounds of grain.

How well does it work? At first I was getting what seemed to be too much flour. I backed off the crush plate and it seems to do much better now. I took the mill to my club meeting. The brewmaster for

the microbrewery where we meet checked out the crush and said it looked good. I have done one batch, a porter, which is fermenting now. Crushing the grain took longer than I anticipated. Although the roller is about 8 inches long, it does not draw the grain in as quickly as I thought it would. It took me a 30 to 45 minutes to mill the 12+ pounds of grain. Due to an anomaly in the way I put grooves in the roller, one side of the roller draws in grain much better than the other side. More care in roller construction should improve throughput. The sparge flowed free and clear.

I obtained about 29 points per pound per gallon. This is better than I achieved with store crushed grain, but I changed several other aspects of my mashing (new lauter tun, and pH adjustment) so it is not a fair comparison. I also probably could have had more extraction. I stopped sparging because I had gathered all the wort I needed (7 gallons). Both the gravity and pH of the runnings were still in an OK range for continued sparging. (Gravity 1.013 and pH still under 6). The point is that extraction seems to be in line with what homebrew-ers normally see, so the mill must be crushing OK.

After crushing grain for one batch, including some dark crystal and chocolate malt, I can see a few indentations in the wood roller made by the grain. It is not serious enough to affect anything and it looks like the roller will last a long time (I do 12 - 15 batches a year, so I anticipate years of use before needing to replace the roller).

One word of caution: I have never used carapils malt, but I hear it is extremely hard. Crushing it in a wood roller mill may tear up the roller. I figure that I will simply buy the carapils pre-crushed if I ever use it since it would be a small portion of the grain bill.

## **Roller construction**

This is the most critical part of building the mill. The roller must spin true and even on a shaft. In my first try I turned a roller on my lathe, then tried to insert a shaft into both ends. To do this you must drill a hole in the exact center of each end of the roller (or all the way through the exact center.) This is virtually impossible to do. As careful as I was, the roller had an unacceptable wobble. The second attempt at roller construction worked much better and is described below.

Hardware purchased:

- 3/8 inch steel rod. Purchased at the hardware store for \$3 US

The roller should be made from a hard wood. I used black walnut because I had it in the shop. Hard maple would also be a good choice, but I think the way the grain is in oak would not work too well. You need to create a 4 x 4 block of wood with a steel shaft going through the center. Glue together pieces of wood to create a 4 x 2 3/16 block and a 4 x 1 13/16 block, each 8 to 9 inches long. (Use wood glue and clamps and the blocks will be stronger and more stable than solid pieces of wood.) In the center of the 4 inch surface of the thicker block, cut a 3/8 inch wide by 3/8 inch deep channel the length of the block. In this shaft, epoxy the steel shaft. The shaft should extend beyond the block about 2 inches on one side and 6 inches on the other. Before epoxying the shaft, sand the portion that will be inside the wood and use a hack saw

to make small indentations in the shaft for the epoxy to grip. Do not sand the part that sticks out of the wood because this part of the shaft will be riding on the bearings. Use plenty of epoxy, but make sure that it stays flush or below the surface of the wood. After the epoxy hardens, glue the smaller block of wood to the larger to form the 4 x 4 block of wood with a shaft through its center. If you would like a larger roller, simply create a larger block of wood (larger rollers reportedly work better.) You are now ready to turn this block of wood on a lathe to form the roller.

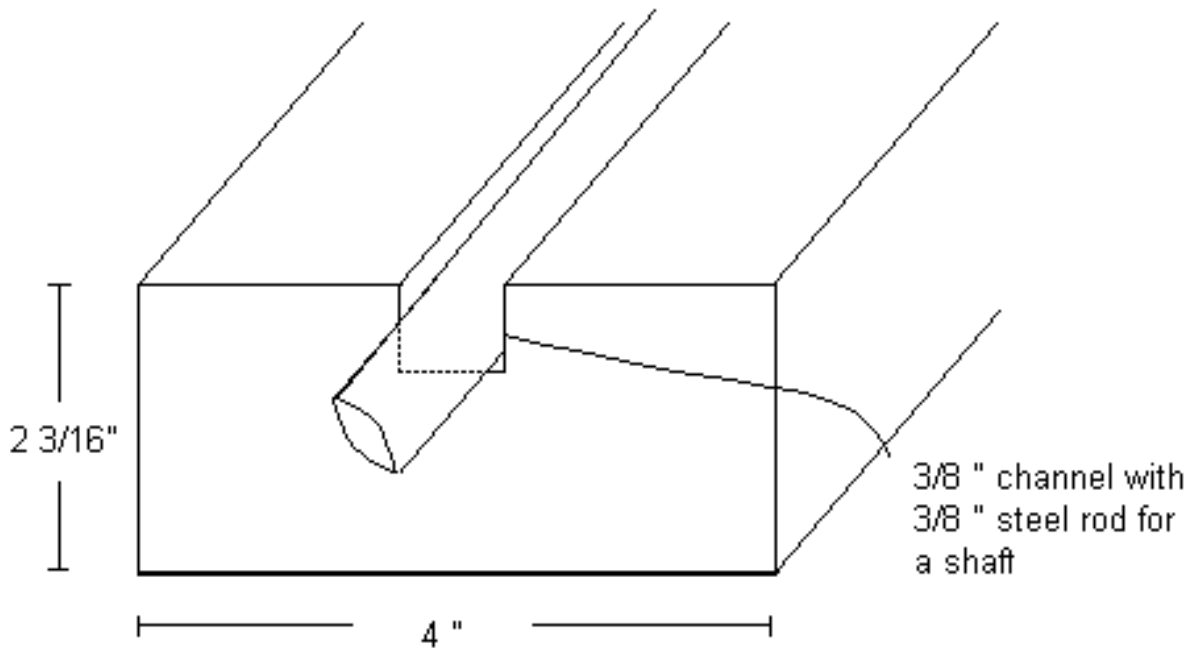

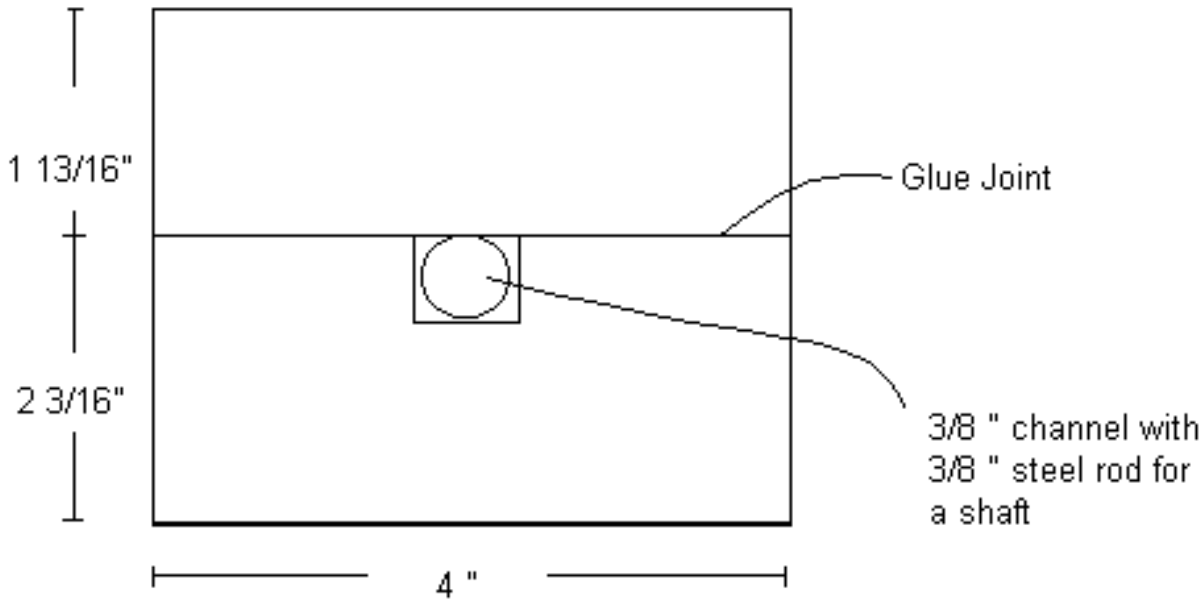

Since the shaft is sticking out both sides of the block of wood, getting it onto the lathe may be tricky. I have a Shopsmith and was able to set things up fairly easily. I will describe my setup for the lathe, but yours may vary. The key is to be creative (but safe) in how to connect the shaft into your lathe.

I put the 1/2 inch drill chuck on the drive shaft instead of the lathe attachment. I then put one end of the shaft in the drill chuck just like you would put in a drill bit. For the other end I clamped a piece of wood to the Shopsmith and mounted into this a bronze sleeve bearing. The shaft coming out the other side of the wood block rides in this sleeve bearing. The result is the exact center of the spinning wood is the shaft.

Turn the wood so that it is of a uniform thickness across its entire length. Calipers are good for checking this. Use a straight edge to make sure there is no waviness or unevenness across the surface of the roller. With a 4 inch block, I expected to get about a 3 3/4 to 3 1/4 inch roller. By the time I had everything even and uniform, I had a 3 1/4 inch roller. It all depends on how good you are with a lathe.

Be careful of sanding on the lathe. Some pieces of wood in your glued together block will have a slightly different hardness than others. Hardness can even vary in one piece of wood. Wood from the center of the tree is harder than wood from the outside. When sanding on the lathe the softer wood will sand away faster than the harder wood, creating a not-quite-round roller. Get the roller even and true with lathe tools, then do just enough sanding to smooth the surface. Do not attempt to even things up with sanding. I tried making things even by sanding on my first roller and ended up with a slightly oval roller (in addition to the wobble described earlier).

On each end of the roller, use a lathe tool to cut the end off all the way down to the shaft. This is to make

sure that the end is square to the roller surface and smooth. This will take off the ridge and extra glue on the end of the roller from gluing the two pieces of wood together. You can also cut the side in slightly as you approach the shaft to minimize side contact of the roller with the sides of the mill.

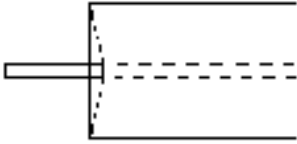

The next step is to put grooves in the roller to enable it to grip and draw in the grain. These grooves are not done on the lathe. They need to go along the long part of the roller surface, parallel to the shaft.

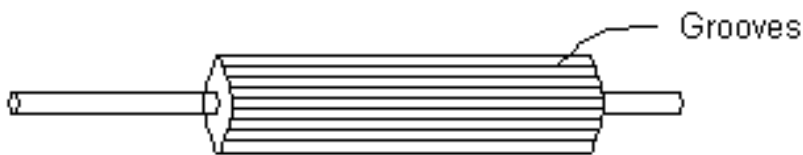

I know of two methods for doing this. The first method uses a table saw. I used this on my first roller, which never made it to a working mill for testing, but the grooves look like they are fine. Adjust the saw blade so that it is at a 45 degree angle to the surface of the roller. Adjust so that the blade will cut about 1/8 inch into the roller. This will give 1/8 inch "V" shaped grooves in the roller. Space between 1/8 and 1/4 inches apart. I had a little bit a trouble with this method because as I pushed the roller along the table saw's surface, It fell slightly into the slot that the saw blade sticks through. I ended up with some grooves larger than intended.

For my second roller, I used a pointed router bit in my Shopsmith and a improvised router table. Because of the way I set things up, the groove on one side of the roller is a little too shallow and does not draw the grain as well as the other side. On a conventional router table this would not have happened.

## The Mill Body

Hardware purchased:

- 2 bronze sleeve bearings with flange 3/8 inch ID (\$2.50 US each)
- 4 screw/bolt things (I can't remember the name). They are basically bolts with screw threads on the other end instead of a bolt head. That is, threads for a nut on one end and screw threads on the

other.

- Also nuts and washers for these. (I don't remember the price, but it was not much.)
- 1 thin piece of shiny brass plate (about \$1 US)

Well, a picture is worth a thousand words, so I am going to let pictures do most of the talking.

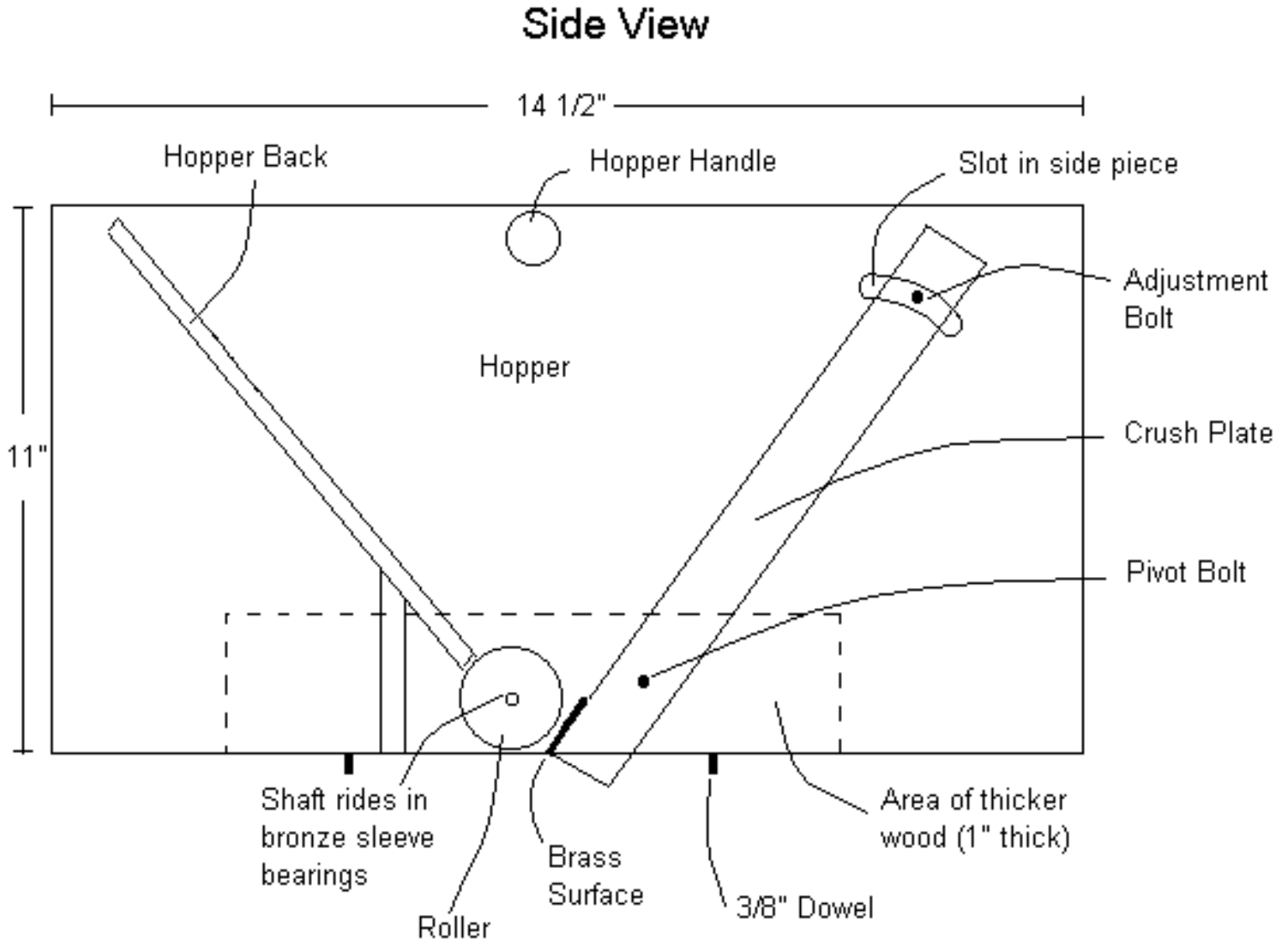

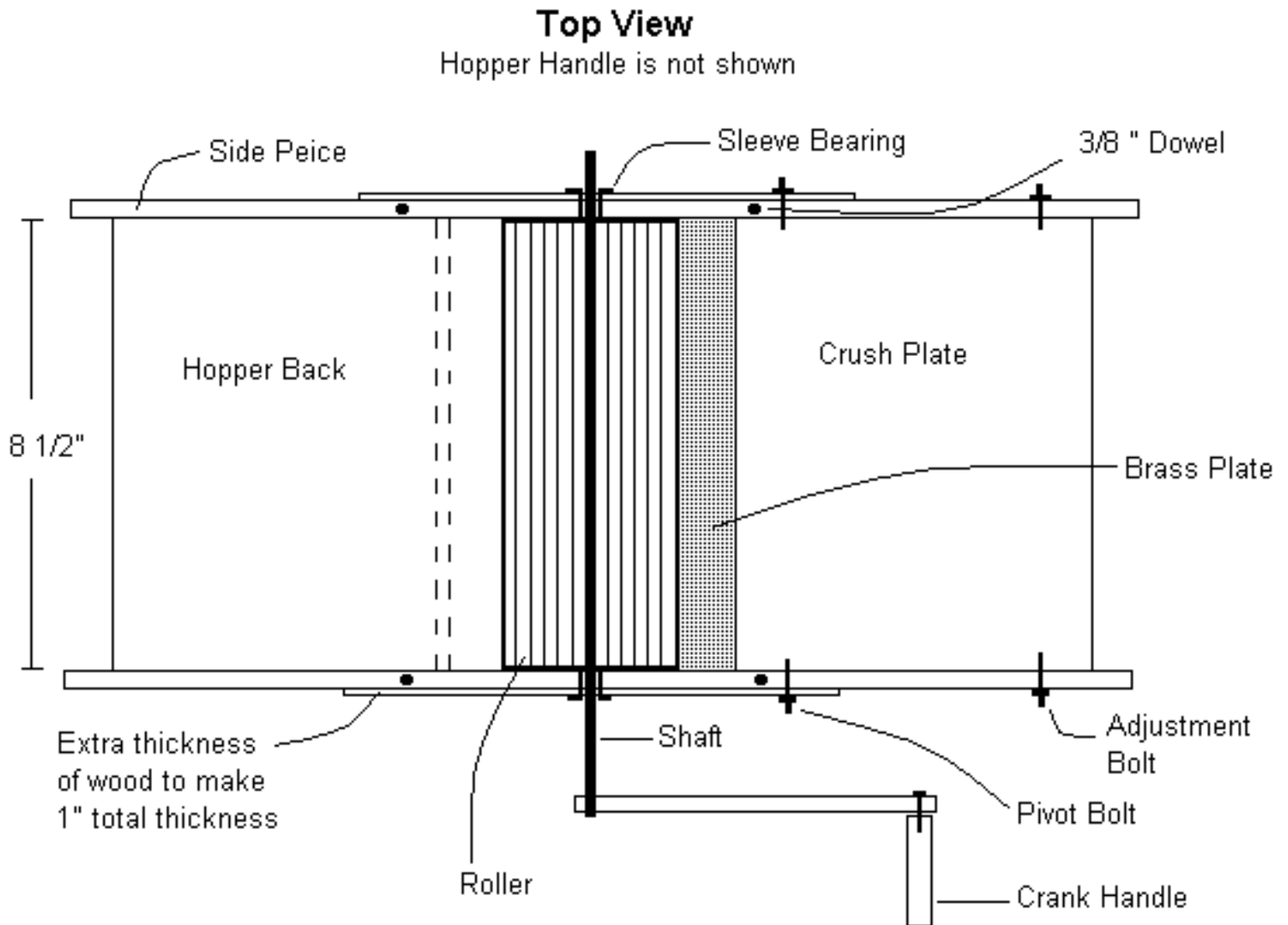

The overall size of the mill is up to you. The larger it is, the more grain the hopper will hold. Mine holds 6-7 pounds of grain.

The sides are the inside layers of the plywood are soft. When the nuts are tightened, the oak surface cracked because the soft wood underneath compressed, forming an indentation. Solid hard wood will have a much smaller indentation.

I used walnut for the hopper back pieces, but most woods that are not too soft should work. Soft wood like pine may not hold the screws very well.

The hopper handle is simply a 1 side of the mill. It simply provides a convenient place to hold the mill while cranking, and is therefore optional.

The area of thicker wood is there for the hole where the bearing is drilled. This is needed because the sleeve bearings are one inch long. The wood must be one inch thick so that the bearing does not hang over

the inside surface of the side of the mill. I glued in place 1/4 inch thick walnut for this, but any hard wood should work.

The sleeve bearings are epoxied into the bearing holes. Note that I clamped the two side pieces together when drilling all holes so that I am sure that they are in exactly the same place on both sides. The critical holes are the for the sleeve bearings and the pivot bolts. Use a drill press to make sure the holes are straight and perpendicular to the surface of wood.

The crush plate is 1 urface-to-surface to get this. I used walnut, but any hard wood should work. I do not know if this thickness is necessary, but since the crush plate realizes all the force of the crush, I figured best to over-engineer. The place on the crush plate where the grain will actually be crushed is covered with a thin piece of brass plating. This plating is no more than 1/16 inch thick (if that) and can be purchased at most hardware stores. To attach it to the wood, sand one side and epoxy it to the wood crush plate in the proper place.

The pivot and adjustment bolts are the screw/bolt things. The screw side is screwed into the side of the crush plate, leaving the bolt side sticking out to form a stud sticking out of the side that washers and nuts can go on. It is important that the holes for screwing the pivot bolts into the crush plate be drilled in exactly (or as close as possible) to the same place on both sides.

Adjustment of the crush plate is achieved by moving the top forward and back so that it pivots on the pivot bolt. The adjustment bolts slide through slots cut in the sides of the mill with a router and are tightened to lock the crush plate in place.

The hopper back pieces exist simply to form the hopper and help hold the two side pieces. The hopper back, crush plate, and hopper handle should all be cut to exactly the same width. This is best achieved by setting up the table saw once, then cutting all pieces with the same setting. The width should be about 3/32 of an inch more than the length of the roller. This provides enough freedom for the roller to spin unhindered between the sides without enough of a gap for grain to get caught in. The two side pieces are held together only by these pieces. The pivot and adjustment bolts are used for the crush plate. The other pieces simply use wood screws. The side pieces are not glued to any of the inner pieces so that the roller could theoretically be replaced in the future. Glue is really unnecessary since this mill is quite sturdy.

The 3/8 inch dowels stick out of the bottom about that they just fit inside of a 5 gallon bucket. When grinding on top of a 5 gallon bucket they prevent the mill from sliding around.

## **The Hand Crank**

The arm of the crank is simply a 1 x ng with a 3/8 inch hole drilled in both ends. The handle is attached with a bolt through one hole in the arm screwed into a hole drilled into the end of a 1 inch dowel. The bolt should have a smooth area near the head where it will ride in the hole in the arm. I recommend oak, or the hardest wood you can get for the handle. The reason is that threads do not hold well in end grain unless the wood is very hard. If you have trouble, try putting epoxy in the hole before screwing in the bolt.



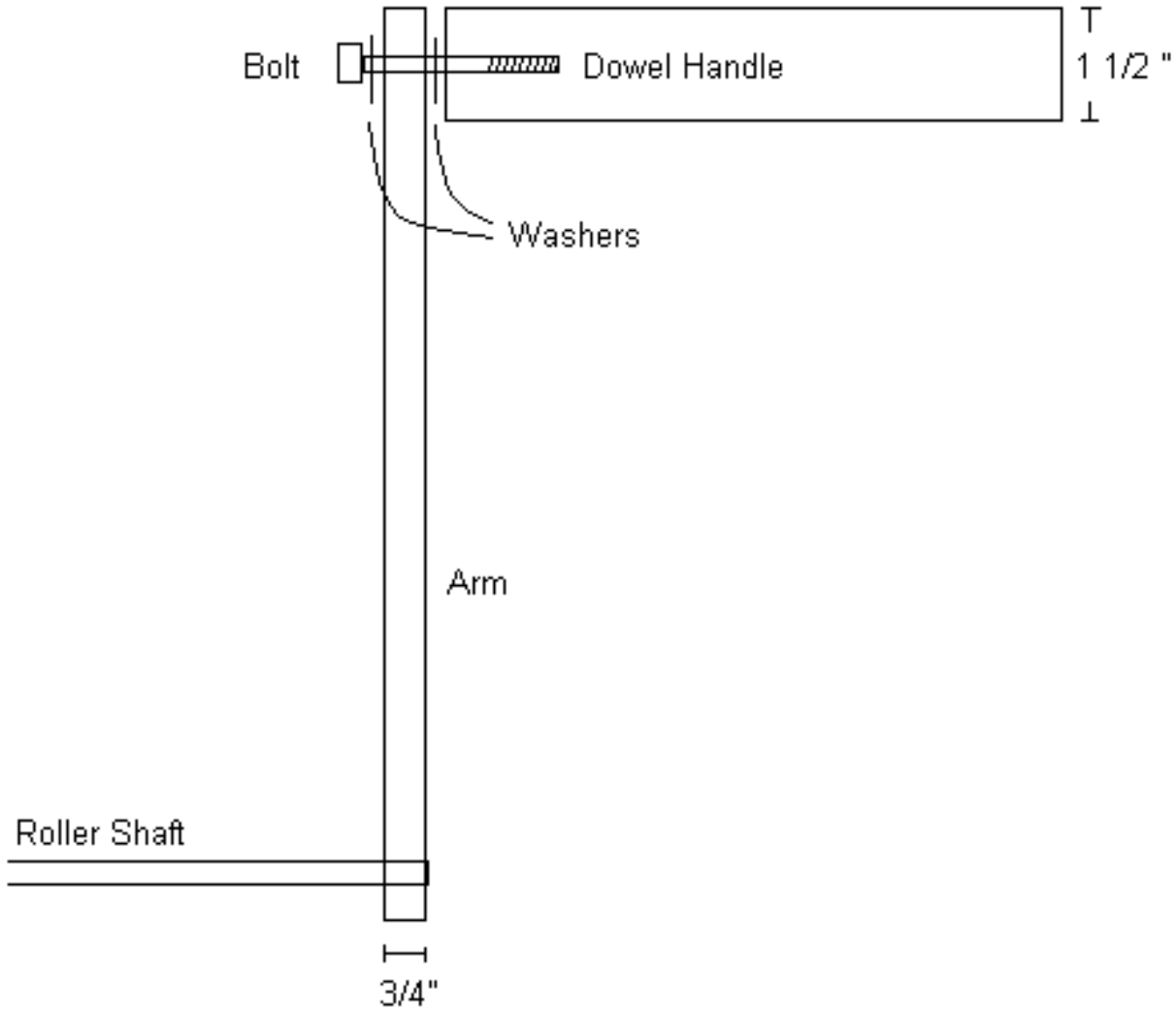

The arm is attached to the long side of the shaft coming out of the roller. Attaching the arm to the shaft should be the very last thing you do to complete the mill. Once the arm is attached, the only way to completely disassemble the mill is to cut the arm off the shaft with a hack saw.

To attach the arm securely, there needs to be a flat surface cut into the end of the shaft. Create this surface using a hack saw, cutting first down the length of the shaft for about in the arm must be widened to form an oval. Do this using a strait router bit set to about 1/4" on the other.

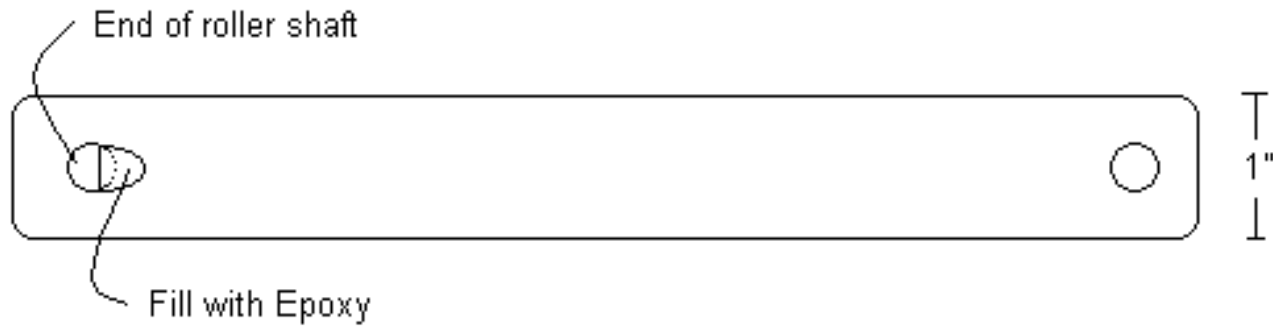

Put the roller shaft through the round side of the hole in the arm so that the end of the shaft is flush with the oval side of the arm. Line up the flat part of the shaft with the open oval area so that one large cavity is formed. Fill the cavity with epoxy and let harden. It is also good to use epoxy all over the end of the shaft to get a good bond.

## The Finish

After sanding, I finished everything except the roller with 2 coats of water-based polyurethane, sanding between each coat. This provides a sealed smooth surface that can be cleaned by simply wiping with a rag. I put on the finish with the major components disassembled (sides, hopper back pieces, crush plate, hopper handle and hand crank) so that the whole mill can adjusted and disassembled.

Be careful when sanding the sides of the hopper back pieces, hopper handle, and crush plate. The part that meets the sides of the mill must remain square and true. I recommend not sanding them at all before the first coat of finish. After the first coat, sand just enough to smooth out the grain that was raised. Be careful not to allow drips or runs along these edges or else they will not sit square against the side pieces.

I debated putting a finish coat of the roller. I was not sure if the polyurethane would come off during crushing. If it did come off, would it affect my beer? Would it be safe? If very small splinters of wood come off into the mash is that a problem? I do not know the answer to these questions, but in order to control small splintering of the roller, I decided to use one coat of water-based polyurethane. Then I sanded off the raised grain of the wood, leaving the sanding scratches on the roller. I thought that the polyurethane would mostly soak into wood and help hold the wood fibers together at the surface. After milling one batch it looks like it was a good idea. I see no places where the finish has come off, and no splintering of the roller surface (just some indentations from grain, probably the harder dark crystal malt). Bottom line is that you need to decide if the polyurethane is OK on the roller. Some polyurethane may come off in the crushing action and get into your mash, and I have no idea if this is safe. Basically, do this at your own risk, I am not responsible. (Obviously I did not think it was that big of a deal, but I want no legal liability. If anyone knows for sure of the safety of this, please let me know and I will update this document.) Polyurethane on the crush plate is not an issue because the grain is crushed against the brass

plate. Do not put polyurethane on the brass plate.