

Above, Fig. 3: Lighting up an experimental gas producer on an M.G.  
 Right, Fig. 1: Lightweight trailer for holding the gas-bag

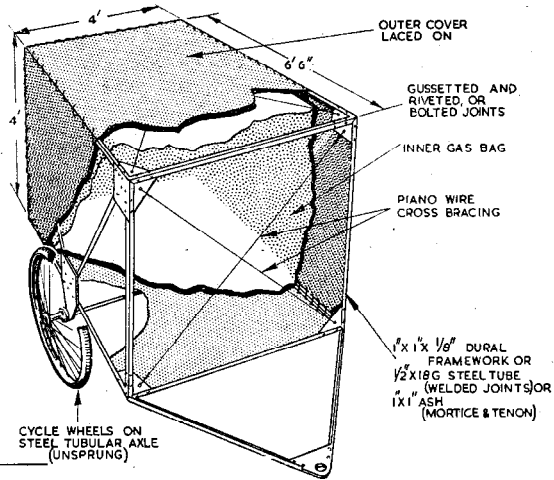

## MOTORING without petrol

By D. H. Chaddock

**T**HE ADVENT of petrol rationing, for the third time in a lifetime, refocuses attention on to the possibilities of alternative fuels. By now all likely and unlikely substitutes have been fairly well explored and the mystical tablet which will turn a gallon of water into a gallon of "coupon free" remains, and is likely to remain, as elusive as ever.

The only alternative liquid fuels which can be used without engine modification are the true synthetic petrols produced by the hydrogenation of coal or tar oils and industrial alcohol, produced by the fermentation and distillation of vegetable material.

Although it might not be beyond the scope of a really resolute model engineer to produce his own industrial alcohol, the operation is a hazardous one, particularly in the latter stages of distillation, and beset with many legal limitations.

We are left, therefore, with coal as our most likely source of energy and we must convert it into gas to provide fuel for a normal i.c. engine. Straight away it can be said that the gas companies do this most efficiently and ordinary town gas is the most convenient and practical alternative fuel for application within its limitations.

Prior to the 1939 war the Birmingham Corporation Gas Department carried out a long series of investigations into the use of compressed gas and were able to show that by using lightweight high-tensile steel bottles charged to 3,000 p.s.i. a practical system could be evolved. However,

the capital cost of the bottles and of the necessary high-pressure compressing plant was heavy. In peace-time the proposition was not economic and in war the necessary materials were not available.

Without compression one is left with the storage on the vehicle of gas at normal pressure and the gas bags of the 1914-19 and 1939-45 wars will be familiar to many readers. Gas-bags on the roofs of vehicles were never very satisfactory: they shook and flapped in the wind when the vehicle was moving and eventually frayed and tore. It was not until the latter part of the 1939 war that the idea of carrying the bag on a trailer was evolved and this proved to be a far better solution.

Because of its bulk, low-pressure gas can never be a complete substitute for petrol, but faced, say, with a daily five mile journey out and back either to a railway station or the office one has either to use the whole ration for this purpose or to use an alternative fuel for the short distance journeys, keeping the petrol ration in reserve for longer journeys.

This is when the gas-bag trailer comes into its own. It can be hitched to the car for local runs and left behind when longer distances than its capabilities admit are envisaged.

Depending on the type and condition of the engine, many tests have shown that between 250 to 350 cu. ft of ordinary town gas of 500 B.Th.U. per cu. ft are equivalent to one gallon of petrol. For a daily run of 10 miles with a car that does 30 m.p.g. one-

third of a gallon of petrol would be needed or, taking an average of 300 cu. ft to the gallon, 100 cu. ft of gas.

This can be stored in a bag 4 ft x 4 ft x 6 ft 6 in., which is a very reasonable size to tow even behind a small car. A special lightweight trailer to carry the bag can easily be built since the weight of the bag is negligible; indeed when it is full it is lighter still!

The sketch shows a typical design. The framework can be constructed of light alloy angle sections bolted together, steel tubes with welded joints, or even wood, depending on the facilities available. Two cycle wheels should be sufficient to carry the weight, which ought not to be more than 50 to 60 lb. Springing of the axles is hardly needed in a vehicle which is only to be used for short mileage local work.

The important feature is an outer cover of canvas or other fabric which is stretched tightly over the framework and which protects the bag inside from damage. The construction is in fact very reminiscent of an airship in which there is a stress-carrying framework, an outer fabric skin and internal gas balloons, and there is considerable scope for ingenuity in producing a gas-bag trailer that is light, simple and inexpensive.

A carburettor or gas mixing valve is needed to supply a combustible mixture to the engine. The existing petrol carburettor need not be removed; simply put a switch in the petrol pump circuit if it is electrical, or a tap between the pump and the carburettor if mechanical.

The gas mixer is connected to the carburettor intake, but if this upsets

the mixture slightly, or if much running is to be done on petrol, provide an alternative unrestricted air intake or retune the carburettor.

A typical gas mixing valve is shown in Fig. 2, reprinted from the *Journal* by permission of the Institution of Mechanical Engineers. The sliding piston, suction operated, can be adjusted to give a correct mixture at all engine speeds, but if one is prepared to do a little knob twiddling a much simpler mixer with a manually operated slide, rather like the old "Binks" motorcycle carburettor, will give quite reasonable results.

Gas is a much more tractable fuel to mix than petrol, the only essential in a mixer being a light spring-loaded non-return valve which will prevent the flow of gas from the container until engine suction is applied.

Filling arrangements need not be elaborate; an ordinary "poker point" will pass about 35 cu. ft per hour so that refilling 100 cu. ft, which must of course be done in the open, will take about three hours. Town's gas at a normal domestic rate of 2s. per therm (200 cu. ft) is equivalent to petrol at 2s. 6d. a gallon, which, to say the least, is cheaper *and* legal!

Although town gas undoubtedly provides the quickest way of \*getting in some coupon free motoring before rationing ends, the true experimentalist will probably be attracted to the more-difficult problem of producer gas.

In a producer gas generator, solid fuel is burnt with a controlled and

limited supply of air, so that a gas rich in carbon monoxide and itself inflammable is evolved. This gas in turn, when mixed with a further supply of air, forms an explosive mixture which can be used in a conventional i.c. engine.

During the early part of the 1939-45 war I made some fairly extensive and reasonably successful experiments in this direction but the work stopped under the combined pressure of service in the forces, solid fuel rationing and licences for the purchase of material.

Fig. 3 shows the very Heath Robinson but workable outfit attached to the rear end of an M.G. Midget. It cost practically nothing to build; two distemper drums, a large sweet tin, some 1-1/2 in. water-pipe and fittings and an old Zenith carburettor provided essential raw materials. Although working drawings of a more presentable outfit were produced and copies distributed to certain interested parties they cannot be reproduced here because the tracing was finally lent to someone else who never returned it. If this should chance to catch his eye I should be glad to have it back!

However, to deal with each item from memory, the producer is mainly an empty cylinder which must, however, be airtight. The distemper drum was made so by luting the lid and holding it down by cross straps and tension bolts, but a more refined version would have a "smokebox

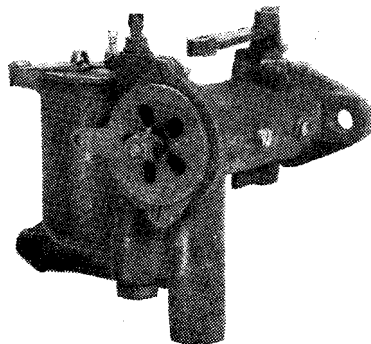
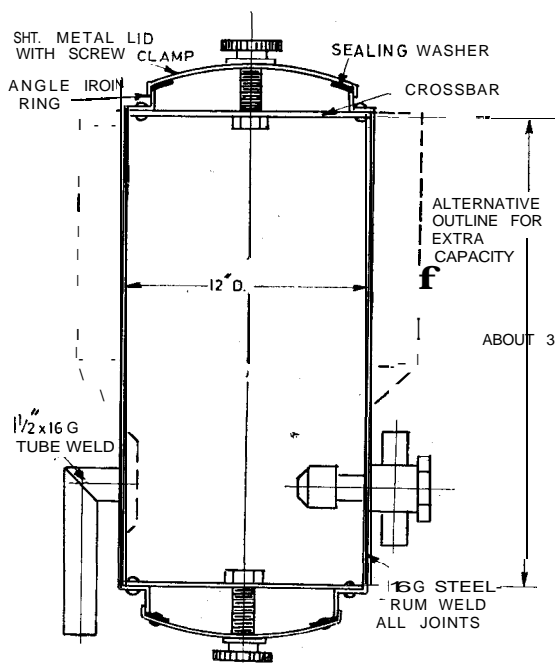
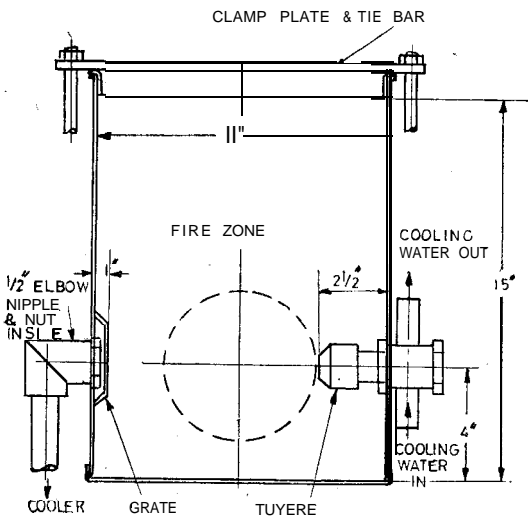

**Fig. 10: An old-fashioned Zenith carburettor which was successfully converted to gas operation**

door" type of arrangement top and bottom; one for filling and one for emptying. Emptying the distemper drum could only be done from the top, first with a shovel and then with the fingers—a messy operation.

Air for the tie is introduced through a water-cooled tuyere, very similar to that, used in a blacksmith's forge (Fig. 6). The tuyere was made from standard water fittings and proved very successful, so there is no reason why this form of construction should not be repeated.

The important dimensions are the internal diameter and the distance which it protrudes inside the drum. The sizes shown were found to be just about right for an 8 h.p. engine,



*Above, Fig. 4: Distemper drum producer; and right, Fig. 5: Final design of gas producer*

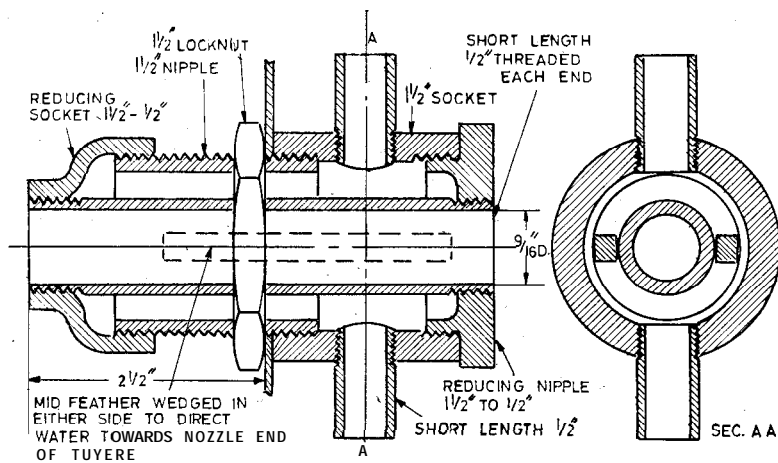

Fig. 6: Watercooled tuyere built-up from standard water-pipe fittings; the mid-feathers in the cross-section on the right extend to the walls of the t,

but it is better to have the tuyere hole too large than too small to begin with as it can always be closed up a bit by knocking in a tightly fitting

If it projects too far into the drum the air will not be gasified before it leaves and a weak gas will result. If it does not project far enough the fire will burn against the side of the drum and burn it out. The ideal is to have a ball of incandescent fuel around the nozzle of the tuyere but dead fuel all around it to protect the walls of the drum from overheating.

Gas leaves the producer via a simple sheet metal grate which holds back the solid fuel and will not overheat if it is correctly spaced in respect to the tuyere.

The tuyere itself is watercooled by

simple thermo-syphon action from water contained in the tank or sweet tin. This was found to be very effective for the water in the tank kept quite cool with the draught of air around it, and no pump or radiator was required as the hoses were short and direct.

The hot gas from the producer must be cooled before it is filtered so I arranged a zig-zag of four 4 ft lengths of 1-1/2 in. water-pipe coupled together and clipped to the chassis frame (Fig. 8). This was rather heavy and could undoubtedly have been made lighter and more efficient if welded up from lighter gauge steel tube. The ends of the pipes should be closed by removable caps to facilitate occasional "tube sweeping."

From the cooler the gas passes into the second distemper drum which must perform the vital operation of

removing the dust and grit drawn over from the fire. The filter is really the heart of an efficient producer system; on the one hand it must not offer so much restriction, even when dirty, that the flow of gas is impeded, and on the other hand it must really protect the engine from all the nastiness inherent in all forms of solid fuel.

The design illustrated (Fig. 9) proved to be reasonably efficient in use and had the merit of being simple to make. The lower part forms an oilbath dust trap and the upper part an oiled sisal scrubber. After it had been assembled dry, a gallon or so of old sump oil was poured into the gas outlet. This saturated the sisal packing and finally collected in the oilbath beneath.

When the filter needed cleaning the oil was drained out by the bottom plug and the filling process repeated with a gallon of paraffin to wash the dirt out of the sisal. After this had been drained off, the filter was re-oiled, using for the purpose oil from the engine sump which, when one is experimenting with producer gas, it is advisable to change frequently.

From the filter, the now cool, and we hope clean, gas can be taken via rubber hose to the gas mixing valve. The calorific value of producer gas is so low, only about half that of town gas, that any sophistication in the mixing valve by way of automatic pistons or even non-return valves is unjustified.

I successfully converted an old-fashioned Zenith carburettor (Fig. 10) by cutting off the main jet assembly completely and substituting a gas-pipe which admitted gas through a ring of holes drilled in the venturi. The float chamber and slow running

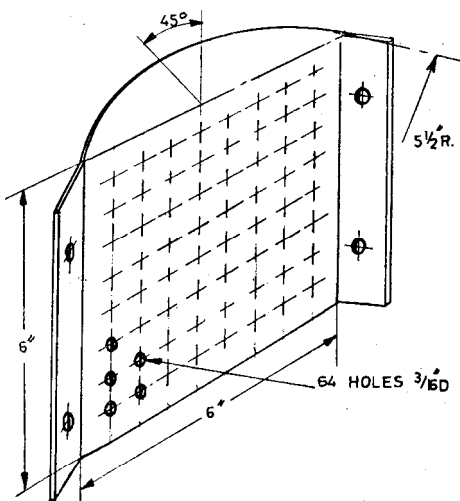

Left, Fig. 7: Vertical grate for gas producer. Use 16-gauge sheet steel

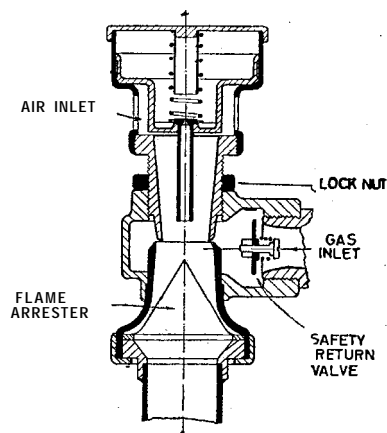

Right, Fig. 2: Suction controlled air valve

jet were retained for starting and the spring removed from the choke shutter so that it would "stay put" and could be used as a mixture control. This simple adaptation proved surprisingly successful and was much easier to control than had been anticipated.

The *modus operandi* for starting was not unduly complicated. With the petrol turned on and the throttle in the normal position the engine was started in the ordinary way. When it was running the air shutter was completely closed, thus drawing all the air through the producer system.

A lump of cotton waste on the end of a wire was dipped in paraffin and lighted. Held against the open end of the tuyere the flame was instantly sucked inside and in 10 or 15 sec. the fuel was alight and the torch could be removed and extinguished.

Under the intense draught the fire spread rapidly and in less than a minute gas was coming over to the engine which began to give the usual signs of "rich mixture." This was the time to turn the petrol off and open the air shutter a little. Before the petrol in the float chamber was exhausted various trial "blips" on the throttle showed whether there was sufficient gas to take the load, and enabled the air shutter to be readjusted.

Once gas generation was well established the engine answered well to the throttle without further manipulation of the shutter, although for idling, the slow running stop was set to a rather higher speed than usual and the air shutter closed a little to ensure an adequate draught through the fire.

A variety of fuels can be used in a gas producer of this sort. By far and away the easiest is charcoal and this is recommended for initial experiments. It is very easy to light, produces a good gas and is clean, but it bulks very light so that a drum full soon disappears, although no great weight of fuel has been burnt.

Anthracite is second best, lights well and makes good gas, but unless it is of very high grade, it contains more ash of a much more abrasive character than charcoal.

Coke is not an easy fuel to use; it will only gasify well under a strong draught and is not therefore very adaptable to the varying demands of a motor vehicle. It can be improved by various simple chemical treatments—spraying with a weak solution of washing soda is one—but it contains a high proportion of fusible ash which readily forms clinkers in the producer and upsets its operation.

Various patent fuels can also be used but as they are made by briquetting coal or anthracite dust with various binding media they need watching. Some use cement as a binder, obviously very undesirable to introduce into a producer system unless the filter is absolutely above suspicion. Others use pitch or tar-like substances and these can distill in the heat of the producer only to condense in other parts of the system, where mixed with the inevitable dust and ash it can make an undesirable conglomeration.

A good deal of running was done with the very simple apparatus shown and although I never ventured very far from home and always carried an emergency supply of petrol on board it is to the credit of the system that it never broke down and I always returned home, as I had left it, "on gas."

Unfortunately my records of various test runs are no longer available but, from memory, a drum of the size

illustrated contained sufficient charcoal for 15 to 20 miles running and about twice as much when using anthracite.

Engine power is unfortunately much reduced and can be best described as one gear down. That is to say the car will climb hills in second gear that it formerly climbed in third gear, and so on. Because of the lack of power, top speed is also reduced but given time and a fair wind 45 m.p.h. was achieved on gas.

The simple producer described had one alarming but not dangerous feature. When changing gear the sudden closing of the throttle and the resultant cessation of gas flow caused a back draught in the producer and a fine yellow flame a foot or so long shot out of the tuyere. This gave rise on many occasions to cries of

"Hi, mister, your car is on fire," but nothing untoward ever happened as the reserve petrol was carried well out of harm's way.

This defect could have been quite easily cured by fitting a simple flap valve opening inwards over the open end of the tuyere, but the writer rather liked the flames—they at least showed that the fire was alight!

So much then for a series of experiments which, even if they did not add much to pleasure motoring, did at least recapture something of the pioneer spirit of the early days in which every ride in a car was an adventure and a trip completed without a breakdown was a triumph that is unknown to the present-day motorist. □

Right, Fig. 9: Details of the washer and filter

Below, Fig. 8: How the pipe cooler is fitted to chassis. The water barrel is 1/2 in. dia.; the tees are 1-1/2 in. dia. and the plugs are also 1-1/2 in.

