

DEVELOPMENT  
TECHNOLOGY  
UNIT

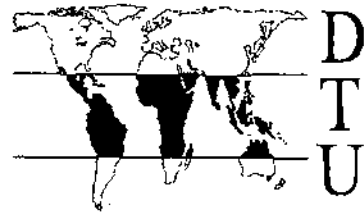

Working Paper No. 40

Quasi-Static Compression Forming of  
Stabilised Soil-Cement Building Blocks

1993

D.E.M. Gooding

Development Technology Unit  
Department of Engineering, University of Warwick  
Coventry CV4 7AL UK  
Tel: +44 (0) 1203 523122 Fax: (0) 1203 418922  
email: dtu@eng.warwick.ac.uk

## Quasi-static Compression Forming of Stabilised Soil-cement Building Blocks

by Dr.D.E.Gooding

### ABSTRACT

This paper examines the quasi-static compression (slowly applied pressure) method of compacting stabilised soil-cement building blocks. It describes a self-contained piece of research which was conducted to enable the comparison of quasi-static compression with the alternative dynamic methods of soil compaction. It gives an initial over view of the process of soil stabilisation and outlines the roles which soil structure and block curing play in stabilisation. The alternative methods of block compaction are briefly described, followed by a discussion of the material factors which affect the compaction of stabilised soil. A number of simple theoretical models to describe the internal compaction mechanisms of quasi-static compaction are then given.

The results of an experimental investigation to asses the effect of double-sided compaction, mould wall roughness, mould wall taper and pressure cycling relative to the datum process of single-sided, single-cycle compaction are then discussed. This is followed by an experimental investigation to determine the relation between compaction pressure, cement content and seven day wet compressive strength. A formula relating cement content and compaction pressure to wet compressive strength is put forward as the best fit to the experimental data gathered. This formula is then used as the basis for a simple economic analysis of high and low pressure compaction machines.

## CONTENTS

### INTRODUCTION

1. STABILISED SOIL
  - 1.1 THE PRINCIPLES AND PRACTICE OF SOIL STABILISATION
  - 1.2 SOIL STRUCTURE
  - 1.3 THE CURING PROCESS
2. BLOCK COMPACTION PROCESSES, THE ALTERNATIVES
3. MATERIAL FACTORS AFFECTING THE COMPACTION OF STABILISED-SOIL BLOCKS
  - 3.1 MOISTURE CONTENT
  - 3.2 COMPACTION DELAY
4. MODELS TO DESCRIBE THE INTERNAL COMPACTION MECHANISM FOR COMPRESSED BLOCKS PRODUCED BY QUASI-STATIC COMPACTION
  - 4.1 SIMPLE HYDROSTATIC FLUID MODEL
  - 4.2 PIPE FLOW MODEL
  - 4.3 SOLID MODEL (POISSON'S RATIO)
  - 4.4 ELASTO-PLASTIC BAND COMPACTION MODEL
5. MOULDING FACTORS AFFECTING THE COMPACTION OF SOIL-CEMENT BLOCKS
  - 5.1 SINGLE-SIDED COMPACTION - THE DATUM PROCESS
  - 5.2 DOUBLE-SIDED COMPACTION
  - 5.3 REDUCTION IN MOULD WALL FRICTION
  - 5.4 MOULD WALL TAPER
  - 5.5 PRESSURE CYCLING
  - 5.6 SUMMARY
6. THE PRESSURE-CEMENT-COMPRESSIVE STRENGTH RELATION
  - 6.1 INTRODUCTION
  - 6.2 EXPERIMENTAL INVESTIGATION
  - 6.3 THE EFFECT OF COMPACTION PRESSURE AND ENERGY ON SEVEN DAY WET STRENGTH
  - 6.4 THE EFFECT OF CEMENT CONTENT ON SEVEN DAY WET STRENGTH
  - 6.5 THE PRESSURE-CEMENT-STRENGTH RELATIONSHIP
  - 6.6 SIMPLE ECONOMIC COMPARISON BETWEEN MACHINES GIVING RESPECTIVELY 2 AND 10 MPa COMPACTION

APPENDIX A : BIBLIOGRAPHY

APPENDIX B : *SOIL-A* PROFILE

APPENDIX C : EXPERIMENTAL METHOD

APPENDIX D : EXPERIMENTAL INSTRUMENTATION

## INTRODUCTION

The following paper has been produced as the result of an on-going research program to investigate the compaction process used in the production of soil-cement building blocks. It is concerned with the standard quasi-static compaction process. This is the form of compaction normally used in the field by machines such as the Cinva Ram and the Brepack.

The paper is organised into six main sections followed by four appendices containing a bibliography and experimental details. The first section gives an initial overview of the stabilised block technology and briefly describes the roles which various factors play in the final strength of the block. Section two briefly describes the alternative compaction mechanisms and puts this research in context as a reference base for future work to investigate impact and vibration compaction. The third section deals with the material factors which affect the compaction process. The fourth section gives a number of simple theoretical models to describe the compaction process. Section five examines moulding factors which affect the quasi-static compaction of soil-cement blocks. Mould taper, mould roughness, compaction pressure cycling and double sided compaction are examined relative to standard single-sided compaction (the datum process) by recording the pressure transmitted from the compacting soil to the mould walls with an LVDT-based pressure transducer. Section six examines the relationship between compaction pressure, cement content and seven day wet compressive strength. This relationship is then used in a simple economic analysis to assess the cost effectiveness of high and low pressure compaction machines.

### 1. STABILISED SOIL

Some form of soil covers virtually the whole land surface of the Earth. This soil is usually readily processed with simple hand tools into an easily mouldable material which possesses good compressive strength when dry. Given soil's widespread availability, it is not surprising that it was traditionally widely used as a building material.

The major drawback to building with soil in its natural condition is its susceptibility to water. A soil wall may be considered as a load bearing skeleton of silt and sand glued together by clay. This glue-like behaviour when dry is caused by micro-droplets of water which exist at clay particle interfaces. Clay particles are usually electrostatically charged as a result of surface ion substitution. The charge tightly bonds a thin adsorbed layer of water to the particle's surface. The bonding is sufficiently strong for some adsorbed water to remain even at oven drying temperatures (105-110°C). At the point of contact between two adjacent particles, a micro-droplet of water can exist where the two adsorbed water layers come into contact. These micro-droplets generate both surface and

capillary tension forces which hold the clay particles together. However, when any significant quantity of water is absorbed into empty soil pores, the droplets increase in size and the capillary and surface tension forces reduce, causing the soil to quickly soften and subsequently swell. On repeated wetting and drying the outer surfaces of a soil wall expand and contract more quickly than the main body. In a comparatively short time this leads to cracking and spalling of the outer surfaces and low durability for the wall. Moreover, if the wall becomes saturated with water the compressive strength may fall sufficiently to allow complete collapse.

When a soil has been treated to reduce the effect of strength loss on water saturation to a low level, then it may be considered a permanent, durable building material and may be called stabilised soil.

### **1.1 THE PRINCIPLES AND PRACTICE OF SOIL STABILISATION**

If a soil is to be used in any but the driest of climates, it should be stabilised against the weakening effect of water ingression if it is to be durable. There are three primary methods of stabilising a soil: by adding a chemical waterproofer to reduce the tendency of the soil to adsorb water, by adding a chemical binder to give a strength mechanism which persists even when the block is saturated, or by compressing the soil to increase its density, hence increasing its load bearing capacity and at the same time reducing its water permeability.

Under normal conditions the soil's density is increased by compaction to reduce the soil-pore void volume and hence its permeability. By reducing the permeability of the soil, the length of time for which a soil wall may be exposed to water without adverse effect will be extended. However, increased density will not stop the ultimate failure of a soil wall if it is allowed to become completely saturated. To maintain strength when completely saturated, the soil must have an additional strength mechanism.

The advantages of increased density complement those derived from the addition of chemical waterproofers and binders, such that it is normal practise to compact the soil block whenever an additional stabilising agent is to be employed. The reduced permeability reduces the speed of water ingress, while the reduction in soil-pore void volume results in a lower chemical requirement. Whether binder or waterproofer, the chemical additive extends throughout the soil-pore void structure. If the volume of the void structure is reduced, then the amount of stabiliser required to fill or bridge the voids is reduced and hence an increase in soil density will usually allow a reduction in stabiliser content for the same final block strength (see section six for more information on the pressure-cement trade off).

When adequately stabilised, a soil block should not collapse when saturated with water, even after several cycles of complete wetting and drying. A waterproofing agent such as bitumen cutback has two effects. It reduces the ability of water to wet individual soil grains and hence reduces the ingress of water. It also provides a secondary method of particle adhesion by weakly sticking particles together. A dry soil block which has been waterproofed with bitumen may be weaker than an unstabilised block as the adhesion power of bitumen is frequently less than that provided by the silt and clay fraction which it is supplementing. However, when subjected to water the unstabilised soil block will rapidly lose almost all of its strength while the waterproofed block will largely retain its lower strength.

A binding agent such as cement will also reduce the effect of water saturation. Again any compaction of the soil during production will reduce the permeability of the soil and reduce the soil pore-void volume. The addition of a chemical binding agent does not stop the ingress of water much beyond that provided by the increase in density. Instead the binder provides a secondary method of bonding the soil particles together which is independent of the soil's water content. In the case of cementitious binders, the stabiliser forms hard insoluble fibres throughout the soil pore-voids. These fibres then effectively form a rigid skeleton which continues to hold the soil particles together even when wet. The addition of cementitious binders to an appropriate soil will improve both the wet and dry strength of the final cured block. The following paper is centred on binder-type stabilisation and in particular the production of stabilised soil-cement blocks where the stabilising agent is ordinary portland cement. Other binders, such as lime, have been used to make successfully stabilised blocks; however cement is the most commonly used stabiliser and as such has been the subject of this research.

Regardless of the type of stabiliser used, the production process for stabilised-soil blocks is similar. Firstly the local area is surveyed to establish the location of a suitable soil type.<sup>1</sup> Having found a suitable soil or modified a less than suitable one, the soil is dug, sieved to remove any large particles (greater than 6mm) and break up any large lumps. It is then laid out to dry. A suitable quantity of stabiliser is mixed with the dry soil and a uniform mixture is produced. A suitable quantity of water is then mixed with the soil such that the resulting mix is at the optimum moisture content (see section 3.1) for compaction. This mixture is transferred to the block mould for compaction. After compaction the "green" block is ejected from the mould and transferred to a curing area, which should be flat, level and protected from rain. The block is left to cure before incorporation in a wall. The curing regime differs according to the type of stabilisation being used. The

---

<sup>1</sup>. The process of soil selection and the discussion of soil suitability is covered in an earlier paper, DTU WORKING PAPER No. 38 "Soil Testing for Soil-Cement Block Preparation."

curing requirements for cement stabilised blocks will be covered in section 1.3.

## 1.2 SOIL STRUCTURE

The soil structure plays a very important role in the stabilisation process. In general use the high cost of soil will dictate the stabilisation of natural local soil. Natural soil exists in layers of differing composition. The top most layer of soil is generally organic and hence unsuitable for stabilisation. The subsequent lower layers will normally be inorganic and contain differing fractions of gravel, sand, silt and clay, and may or may not be suitable for direct stabilisation. If the first inorganic layer is predominantly clayey it will be poor for stabilisation. However, if the second layer is more sandy, a soil more suitable for stabilisation may be produced by blending the two.

Any soil may be described by a particle grading curve and its plasticity or Atterburg limits. The particle grading curve details the proportions of gravel, sand, silt and clay present in the soil while the plasticity limits give information on the properties of the fine (silt and clay-size) components. The different size fractions play different roles within the stabilised block.

Particles of sand size and larger act as the main inert body of the block. These sand and gravel fractions should be present in correct proportions to allow the most dense packing arrangement. The theoretical optimum distribution of particle sizes is that given by the Fuller curve (Fig 1.2a).

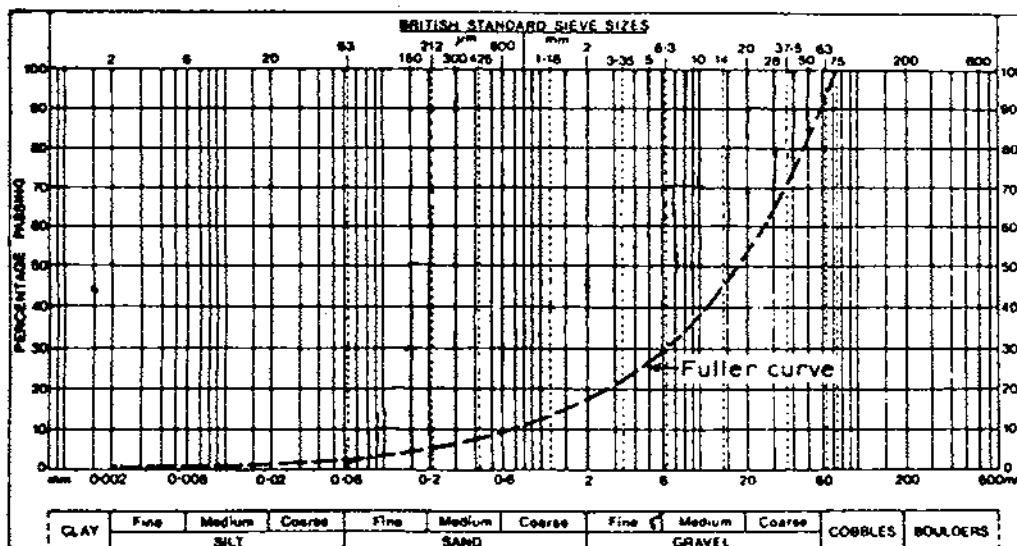

Figure 1.2a The Fuller Curve

The Fuller curve is based upon the assumption that all of the particles are spherical and that the largest particles just touch each other, while there are enough intermediate particles to fill the voids between the largest, but without holding them apart. The intermediate size particles are also similarly arranged with progressively finer particles filling the voids between larger ones. The Fuller distribution is an ideal model and never occurs naturally. However, a natural soil which has an even distribution of particle sizes, termed well-graded, is a good approximation and will ensure adequate packing.

The fine fraction of the soil may be considered as the active fraction. The coarse material is essentially inert, it does not change volume on wetting and does not play a significant role in particle bonding. The fine fraction is responsible for the dry cohesion of a soil. If this fraction is wetted it will expand. Clay consists of a large number of very small usually plate-like shaped particles. In a dry condition these particles pack closely together, held tightly in place by micro-droplets of water. On exposure to more water, capillary suction tends to draw water into the inter-particle fissures and separate the particles. This particle separation occurs simultaneously in three directions such that the clay expands.

The expansion of dry clay on wetting is the source of dimensional variations which can lead to cracking and spalling of a soil-cement block. For block durability, the extent to which the block expands and contracts on exposure to water should be minimised. A stabilised soil-cement block exhibits less dimensional variation than an equivalent unstabilised block. The force exerted by the expanding clay fraction must be resisted if the block is to remain intact over any significant length of time. In the case of soil-cement blocks this expansive force is largely resisted by the confining action of the insoluble cementitious matrix. Hence a large clay content soil will require a large quantity of cement to stabilise it. In order to minimise this expansion for a given water exposure level, and hence the amount of cement required, it is necessary to reduce the clay content of the block to a minimum.

However, the cohesive strength of damp clay is largely responsible for the green strength of the freshly formed block. Indeed a pure sand will exhibit negligible cohesion when dry and only slightly more when damp. It is most important to the economics of soil-cement block production that the fresh block can be ejected from the mould immediately after compaction rather than the cure-in-mould approach seen in conventional concrete work. To enable immediate ejection after compaction, the fresh block must have enough strength to allow at least careful handling without damage.

Hence it can be seen that the clay fraction is both a help and a hindrance to block production and a compromise must be reached. The extent of the compromise and the "optimum" clay content will be different for each particle grading and type of clay, montmorillonites for example exhibiting a much higher



expansion on wetting than other types of clay. Moreover, the compaction pressure used to form the block also plays a role. At high compaction pressures the soil particles are forced into more intimate contact which increases the green strength of the block for a given clay content.

The sensitivity of the soil's Optimum Water Content (discussed in more detail below) also depends on the soil's structure. The enormous range in particle size from gravel (6mm) to clay (less than 0.002mm) results in a large difference in the specific surface area (SSA) of soils containing different proportions of different sized particles. When a soil is made up of predominantly fine material then the SSA of that soil is very large, when the soil contains larger fractions of more coarse material then the SSA is reduced. For a high SSA soil, a given change in water content will have a reduced effect on the compaction process as the area over which the water acts will be relatively large and result in only minor physical change. Conversely for a low SSA soil, the area over which the water acts is reduced and hence the physical effect on the soil is greater.

This effect is illustrated in figure 1.2b (Fig 1.2b). Dry density after compaction is plotted against moisture content at the time of compaction. Curve A shows the pattern for a well graded soil containing a range of particles from gravel to clay size, Curve B shows the pattern for a more narrowly graded soil containing particles from only fine sand to clay size. It can be easily seen that curve A has a more pronounced peak than curve B.

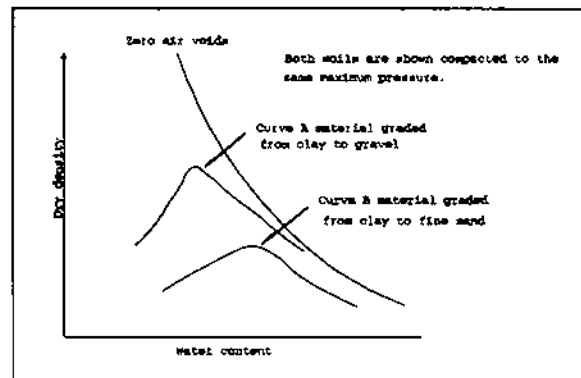

Figure 1.2b Dry density plotted against water content.

It may also be noted that the density peak for curve B is shifted towards higher moisture contents and that the peak dry density is reduced. The increased optimum water content would be expected from the above discussion of SSA while the reduction in dry density would be expected from the discussion on particle grading.

The factors affected by the structure of the soil may be summarised as follows:

**GRADING** The soil grading should be as close to the optimum Fuller curve as practical to enable the most dense packing of the soil particles. The more dense the packing of the soil particles then the lower the permeability of the soil and the higher its compressive strength. The larger the greatest size of particle the more care must be taken in controlling the moisture content.

**PLASTICITY** The soil should contain sufficient clay to allow adequate green strength on ejection from the mould. Too little

clay and the breakage rate on ejection of the compacted block will be unacceptably high. Too much clay and the long term durability of the block will be adversely affected.

### 1.3 THE CURING PROCESS

The curing process described below refers to that required for blocks which have been stabilised with ordinary portland cement. The curing regime will be broadly similar for lime stabilised blocks but the length of time for curing should be doubled. For bitumen stabilised blocks, "curing" is the process of evaporation of the bitumen solvent and of the moisture content required for compaction. The bitumen curing process is primarily a drying operation while that for cement and lime is a period of time for the bulk of a chemical hydration reaction to occur.

In the case of bitumen stabilisation drying out of the block is desirable, provided that the drying is not sufficiently rapid to lead to warping of the block. For cement and lime stabilisation, drying out of the block will stop the cementitious hydration reaction and hence not allow the blocks to gain their full strength.

After ejection from the compaction mould the block should be carefully transported. The green blocks are weak until the chemical hydration reaction has occurred and any significant breakage rate will have an adverse effect on the economics of the project. The safest way to transport green blocks is to place them on individual boards and subsequently carrying the board to the curing site. The blocks may be placed onto and removed from the board by placing the palms of the hands flat against the largest sides of the block and squeezing the hands together just enough to grip the block to lift it.

The blocks should be taken to a flat level area which should be protected from direct sunlight and rain. Direct sunlight would cause the blocks to dry out too quickly, while rain would easily erode the fresh blocks at least until the cement has had time to hydrate. During the first four days the block should be kept damp to allow the chemical cement hydration reaction to occur. It is this hydration reaction which gives the soil-cement block its superior wet strength.

The exact mechanism by which a small content of cement may stabilise a large mass of soil is not fully understood. Ordinary Portland Cement is made up of 45% tricalcium silicate ( $C_3S$ )<sup>2</sup> and 27% dicalcium silicate ( $C_2S$ ). In the presence of damp soil these

---

<sup>2</sup>. C and S represent Calcium and Silicon respectively, not carbon and sulphur. This is in keeping with most of the published concrete literature and is acceptable, allowing these simple equations to be given as illustrations instead of the more complicated fully balanced chemical equations.

components hydrate to form mono and di-calcium silicate hydrate gels (CSH and C<sub>2</sub>SH, see equation below). These gels then slowly crystallise into an insoluble interlocking matrix throughout the soil voids binding the soil particles together. As the matrix is insoluble it gives a strength mechanism which works to restrain the softening and swelling of the unaffected soil, thereby dramatically reducing the weakening effect of water. The interlocking calcium silicate fibres may be seen when a cured soil cement sample is examined under an electron microscope. The hydration of the calcium silicate also results in the release of free lime (CH) according to the reaction:

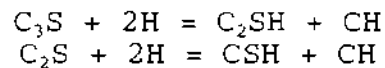

The free lime then reacts further with the clay fraction (pozzolanic reaction) by the removal of silica from the clay minerals and subsequently forms more calcium silicate gel which also gradually crystallises.

## 2. BLOCK COMPACTION PROCESSES, THE ALTERNATIVES.

This paper examines the effects of various process and material factors on the production of soil-cement blocks by quasi-static pressure application. This work has been conducted as a self-contained piece of research but will be used as a reference datum for the future examination of alternative compaction mechanisms, the alternatives being dynamic force application by impact and vibration.

**QUASI-STATIC COMPRESSION:** Quasi-static or slowly applied compaction is the process used by the majority of soil-block making machines. The loose soil is compressed by slowly applying a large force. The magnitude of the pressure which is applied varies from machine to machine but is generally within the range of 1-8 MPa. The Cinva Ram is a well known low-pressure machine which uses force applied manually through a lever mechanism to produce a compaction pressure of about 2 MPa. The Brepack is an example of a high-pressure machine which applies between 8 and 10 MPa compaction. The Brepack uses a lever mechanism for the initial compaction and finishes with a manually operated hydraulic ram.

If a standard block's dimensions are assumed to be 290x140x100 mm then compaction pressures of 2 and 10 MPa equate to static loads of 8.3 and 41.4 metric tonnes. This is an appreciable loading for the structure of any machine to withstand.

**DYNAMIC COMPACTION:** Dynamic compaction is compaction by a mass which has a non-trivial velocity on impact, much like a hammer blow driving a nail into a piece of wood. Dynamic compaction requires far less massive machinery to generate large forces than quasi-static compaction does (to *push* a nail into a piece of wood requires a much greater static mass than that of the hammer). Dynamic compaction may also require less effort from the manual-machine operator.

A preliminary investigation into the efficiency of road compacting machines by the Transport and Road Research Laboratory (Williams and Maclean, 1950, Ref No.21) showed that slowly applied static loading may not be the most effective method of compaction for soil. It appears that dynamic compaction is more effective in terms of the depth of soil compacted.

Single impact and vibration are an extension of the same theme. Vibration may be thought of as a repeated light blow which, although requiring more complicated machinery to implement, does not involve the dropping of large and potentially dangerous weights.

### **3. MATERIAL FACTORS AFFECTING THE COMPACTION OF STABILISED-SOIL BLOCKS**

#### **3.1 MOISTURE CONTENT**

Any soil placed in the mould for compaction should contain a known quantity of water. Earlier literature on the subject has suggested that there exists an optimum water content (OMC) at which the maximum density of the soil may be reached for a given compaction pressure. This is correct. By definition the resulting cured dry density will be highest for a block which has been compacted at its OMC. It should be forcefully noted that the OMC is not a parameter solely dependant on the soil, it varies considerably with the compaction pressure used to form the block. In general, as the compaction pressure increases so the OMC decreases. The content may be conveniently thought of as a lubricant which has adverse effects in excessive quantities. At higher compaction pressure the applied force is greater, the soil particles will move more readily and hence less lubricant (water) will be required.

The sensitivity of any particular soil to moisture depends on the soil's particular composition and has been discussed above with reference to specific surface area. Well-graded soils including a substantial fraction of large-size particles will be more sensitive to moisture content variation than soils with smaller fractions of large size material. The degree of

sensitivity to change in moisture content is an important parameter to consider when producing blocks. If the soil material being used does contain a significant quantity of large size material then the control of the moisture content is more critical.

At the outset of this work a number of tests were conducted to establish the optimum moisture content for the soil used in the subsequent work (artificial soil-A). To this end a number of small cylinders were produced at varying water contents and at both 2 and 10 MPa. The soil used for the testing was well graded and the largest size fraction was coarse sand. This type of soil was found to have a low sensitivity to water (it contained a negligible proportion of gravel-size material), resulting in a flat moisture/density curve. However as a result of the low aspect ratio of the cylindrical mould used, the soil-strength required for successful demoulding was quite high. This emphasised the importance of green strength from an early stage in the experimental proceedings. The OMC at 10 MPa was found to be 8% and the cylinders became too weak to allow demoulding without the most careful and elaborate system at 10%! At lower moisture contents the green samples became progressively stronger. This follows readily from the strength mechanism described above for unstabilised soil.

Although the ultimate compressive strength of the block is important, so too is the green strength of the block. By lowering the moisture content at compaction, the green block produced will be stronger although the final cured strength will be lower. The extent to which the reduction in moisture content will reduce the final strength of the block depends on the nature of the soil. In general a more sensitive soil will show a larger drop in final strength as a result of the larger drop in compacted density. It is usually the case that compaction above<sup>3</sup> the optimum water content will result in a weak green compact. If this green compact is not sufficiently strong to allow handling on ejection then it is likely that the breakage rate both on ejection and subsequent transportation will be high.

Low green strength is one of the major problems for many block production systems. Indeed Dr. Lawson (1992, Ref No.22) found breakage rates to be as high as 50% for blocks produced on a Cinva Ram type machine in Nigeria. If an excessive green breakage rate is found then the water content should be reduced to increase the green strength. It should be remembered that any block which has been broken on ejection or during handling operations is lost. It may not be broken up and recompacted, as the cement hydration reaction will have progressed to such an extent that the amount of remaining unreacted cement would be too low for adequate stabilisation.

---

<sup>3</sup> With low clay content soils even compaction at the OMC may produce blocks with inadequate green strength.

The moisture content at the time of compaction also has an effect on the durability in terms of the blocks' permeability. It has been reported by CRATERRE that compaction at moisture contents less than the optimum will result in a more permeable structure than compaction above optimum. A verification of this work will be carried out at The University of Warwick shortly. CRATERRE use the concept of flocculated and dispersed microstructure to explain this phenomenon (Doat et al, 1979, Ref No.8). At low water contents the plate-shaped clay particles mutually attract each other. The outer edge of one plate electrostatically attracts the centre section of the neighbouring plates, leading to a flocculated clay structure (fig 3.1a). At high water contents, the surface charge of the clay plates is largely neutralised by the surrounding water dipoles and creates a pattern of mutually repelling particles or a dispersed structure (fig 3.1b). However at present the magnitude of this permeability change is not clear. In wet climates where water penetration is likely to be of importance then compaction slightly wet of the OMC may be appropriate to increase the blocks' resistance to water.

In summary, compaction at the OMC will produce the most dense blocks (by definition). Compaction wet of the OMC will produce blocks with a lower green strength on demoulding but possibly a lower permeability when cured. Compaction dry of the OMC will produce blocks with a higher green strength on demould and possibly a higher permeability.

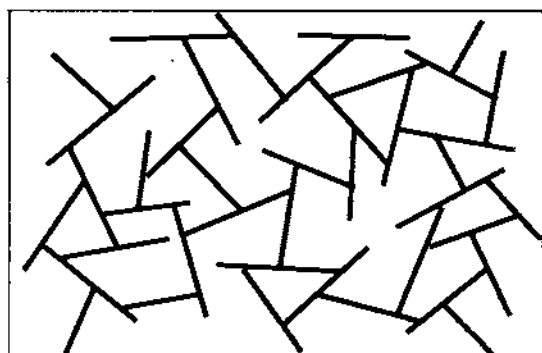

Figure 3.1a Flocculated



Figure 3.1b Dispersed

Compaction at the OMC is the best compromise. In dry climates and where low green strength has been seen to be a problem, the moisture content may be reduced. In wet climates where low green strength has not appeared as a problem then compaction at slightly increased moisture content may be considered. It should be remembered that the final cured strength of the block may be increased and the permeability reduced by increasing the cement content (although this may be costly) whereas the green strength may only be increased by improving the structure of the soil, compacting to higher pressure or reducing the compaction moisture content.

### 3.2 COMPACTION DELAY

The strength of the final cured block depends heavily on the adequate hydration of the cement. Cement is the most expensive ingredient in the production of stabilised soil blocks. Ordinary Portland Cement starts to react immediately on coming into contact with water. The reaction progresses quickly to begin with and progressively slows down over several weeks.

The hydration of the cement produces the insoluble calcium silicate hydrate skeleton which extends throughout the soil voids. This skeleton provides the restraining mechanism which gives soil cement its superior wet strength. The precipitation of these fibres begins as soon as the cement comes into contact with water. The fibres' effect is significantly reduced if they are deposited as discrete entities rather than as a continuous skeleton. Most of the fibres which form prior to the compaction of the soil cement mix will be broken during the pressing process and are then not as effective. The most effective precipitation occurs after the compaction process when the soil particles will remain undisturbed. As a result, the final strength of the stabilised block depends to a degree on the length of time for which the cement is exposed to water prior to compaction. Ingles and Metcalf (Ingles & Metcalf, 1972, Ref No.10) have reproduced a graph from G.West which indicates that over 50% of the final strength of cement stabilised soil may be lost by a delay of 2 hours (Fig 3.2a). Even after half an hour West indicates that between 30 and 40% of the strength is lost. A set of trials conducted at The University of Warwick on cylindrical test compacts has failed to convincingly reproduce such dramatic results. This may be because the short curing period used (seven days) was insufficient, not allowing the samples to cure for long enough to develop sufficient strength for adequate testing in the compression-test equipment available. However, a general trend was observed confirming some loss in (seven day) strength with increased delay between water addition and compaction. A 2 hour delay in compaction produced a strength loss of about 20%.

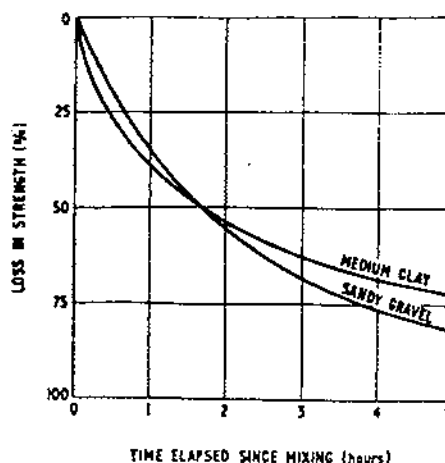

Figure 3.2a Cured strength loss due to compaction delay

#### **4. MODELS TO DESCRIBE THE INTERNAL COMPACTION MECHANISM FOR COMPRESSED BLOCKS PRODUCED BY QUASI-STATIC COMPRESSION.**

A number of simple models were initially postulated to describe the internal compaction mechanism; a simple hydrostatic fluid model, a pipe flow model, a solid model (based on Poisson's Ratio) and an elasto-plastic band compaction model.

##### **4.1 Simple Hydrostatic Fluid Model.**

The simplest model which might be used to describe the compaction process is the hydrostatic fluid model. This model assumes that the soil behaves like a contained fluid, namely that the pressure within the soil is the same in all lateral directions and increases in a downward vertical direction only as a result of the overburden pressure (weight of soil above the layer in question). This overburden pressure is insignificant compared to the external pressures applied to a block during moulding.

This model predicts that if a compaction pressure of 10MPa is applied to the top surface of the mould, both the mould walls and the base of the mould should also experience a transmitted pressure of 10 MPa. It further predicts that there will be no shear force between the soil and the mould walls.

##### **4.2 Pipe Flow Model.**

This model assumes that the soil is behaving like a viscous fluid flowing through a pipe. A viscous fluid may support a shear force while it is flowing. The more viscous the fluid, the longer it will take to flow and the larger the shear force it can maintain. This model predicts that if a pressure of 10 MPa is applied to the top surface of the mould the soil will "flow" downwards towards the bottom of the mould away from the source of high pressure. As some of the applied force is resisted by the mould wall shear force, the force on the bottom of the mould is reduced. As the distance from the compacting piston increases so the area for shear with the mould wall increases. As a result, progressively more force is transferred to the mould walls as a shear force or friction. This effectively reduces the driving force or pressure. The reduced driving pressure then results in a lower lateral pressure than that predicted by the simple hydrostatic model.

The above model is based on fluid pipe flow; flow through an open ended pipe. In the case of soil compaction one end of the mould is fixed and soil is forced towards it by the movement of the opposite end. According to fluid theory, when the velocity of flow reduces to zero, hydrostatic conditions should again prevail as a stationary fluid cannot support a shear force. As the flow of soil may be expected to stop when the compacting



piston ceases to move this zero soil flow should result in equalised hydrostatic conditions, the mould wall pressure should equalise to the simple hydrostatic state mentioned above. If the mould wall pressure does not equalise then either the soil has become so viscous that its rate of flow is too slow to show this equalisation in the time available (typically 30 sec for block production) or that the soil may not be described as a fluid by the end of compaction. If the mould wall pressure does not equalise then the soil must be resisting internal shear forces, behaving as a solid.

#### **4.3 Solid Model (Poisson's Ratio)**

By applying a pressure to the top surface of a solid object, vertical strain is induced in the medium this results in a lateral stress which in turn causes lateral strain. The ratio of vertical compressive strain to lateral tensile strain is defined as the Poisson's Ratio of the medium and is constant within the elastic deformation regime. Typically, for most metals, Poisson's Ratio is around 0.3 (for a fluid it would be 0.5).

Poisson's Ratio is normally used to describe the deformation of unconfined solids when subjected to compressive or tensile stress. A simple unconfined example would be the compression of a steel cube. In such a simple case the Poisson's Ratio is relatively simple to define, the three axial strains being simple to measure and uncomplicated by constraint interference. In the case of soil block compaction this is not the case. Lateral strain is less than it would be when unconfined, as the movement is restrained by the mould walls. The applied stress results in a vertical strain, this producing a lateral stress resulting in a lateral strain. This lateral strain acts on the mould walls, as a result the mould walls deflect. The resistance of the mould walls to the soil deflection decreases the amount of lateral soil strain which can take place.

The mould walls restraining influence further complicates the model as the wall is not completely rigid. The wall elastically deflects as a result of the stress within the soil. The amount of deflection depends both on the stiffness of the wall and the soil stress acting on it. As the wall deflects it provides more resistance to movement as its effective rigidity increases, also as the soil expands so the soil stress is reduced. There should then exist a balanced condition where the restraining force exerted by the wall is equal to the residual soil stress. What effect this residual soil stress will have is unclear. The walls' restraining force may be considered as producing a lateral compressive force which in turn would produce a vertical stress opposing the initial compaction force.

The compaction may be described by this solid model provided that the soil's Poisson Ratio is assumed to change as the compaction cycle progresses. During the initial compaction stage (say up to 10% of the final compaction pressure) a large block

height reduction takes place, typically 80-90% of the total height reduction, with almost no measurable lateral strain. This indicates largely plastic flow; on the removal of the compacting force only limited recovery takes place (typically 1-3 mm, 1/80th of the total deflection). As the block height reduces further the amount of relaxation expansion increases.

#### **4.4 Elasto-plastic Band Compaction Model.**

This model assumes that the compaction proceeds over a set of surfaces arranged roughly parallel with the moving compaction piston. As the compaction force is applied, so the top layer of soil plastically and, to a lesser extent, elastically compresses. As the soil plastically compresses it becomes stiffer and passes more of the applied force on to lower layers which are thus compressing at a slower rate. On decompression the plastic deformation is not recovered but the elastic compression reverses resulting in a degree of material expansion.

### **5. MOULDING FACTORS AFFECTING THE COMPACTION OF SOIL-CEMENT BLOCKS**

Blocks are commonly moulded in a single cycle by moving a piston down into a parallel sided mould containing soil. The mould walls start with some roughness due to machining during manufacture, and this may increase due to soil abrasion during use. This process has been taken as a datum ("standard compaction"). Research was undertaken to better understand the standard compaction process and to investigate a number of variants to it. The pressure transmitted through the soil to the bottom of the mould was taken as a key variable that should correlate strongly with block density and subsequent cured block strength.

The following section examines the effect of the following moulding parameters:

- Double Sided Compaction (instead of single sided)
- Mould Wall Friction (high verses low)
- Mould Wall Taper (instead of parallel-sided mould)
- Pressure Cycling (instead of simple compression)

The effects of the changes in moulding parameters were observed by measuring the pressure transmitted to the mould wall through the compacting soil. The transmitted pressure was recorded by placing an LVDT-based pressure transducer (designed in-house) in seven separate locations in the mould wall and mould piston. The compacting pressure was applied in discrete increments up 2MPa or 10MPa. At each increase in load the block

height, mould wall deflection and transmitted pressure were recorded. Details of the experimental method and the experimental instrumentation are included in appendices C and D.

The initial testing was conducted on blocks made without the use of cement such that the material could be reused and the testing procedure would be less time dependant. Moreover, without the addition of cement the soil mix has a higher internal friction<sup>4</sup> and therefore amplifies the effect of the changes in pressing parameters. It has been assumed that although the magnitude of the variation in the observed parameters will be different for cement mixes, the pattern of change will be similar. Any variation apparent in a non-cement mix is likely to be present in a mix containing cement, but to a lesser degree. Following the initial set of tests two further set of blocks were produced with the addition of cement, one set by the datum process and one by double-sided compaction. These soil-cement blocks were allowed to cure for seven days and then tested for wet compressive strength to asses the actual improvement in strength resulting from double-sided compaction.

All of the blocks produced were made from an artificial soil (Soil-A). This soil has been carefully tested both to BS1377 and by the methods given in the Development Technology Unit Working Paper (DTU) No.38 "Soil Testing for Soil-Cement Block Preparation". The soil is composed of Kaolin grade E powder and a poor quality building sand (high fines content). It has a low plasticity index and is well graded with particles from clay to coarse sand size. This soil has been used to allow repeatable experimentation for the duration of this work and if required the soil may be reconstructed at a later date. By using an artificial soil the large variation in properties of natural soil can be minimised. The details of this soil are included in appendix B.

### 5.1 SINGLE-SIDED COMPACTION - THE DATUM PROCESS

The first case which was examined was that for single-sided compaction. This is used as the datum against which to compare the other cases and as such it is examined in detail. Figure 5.1a shows the pressure variation as recorded by the LVDT transducers<sup>5</sup>. The pressure applied to the top face of the block, via the piston, was increased in small equal steps so as to achieve a uniform increase over time. It was then reduced at the same rate back to zero. After each step pressure and displacement readings were made, the applied pressure being held constant for long enough for these readings to stabilise (quasi-

---

<sup>4</sup> The fine cement particles appear to act like a dry lubricant during compaction. Without cement the soil mix displays higher internal friction.

<sup>5</sup> The detailed description of the performance, calibration and location of the LVDT transducers is given in appendix D

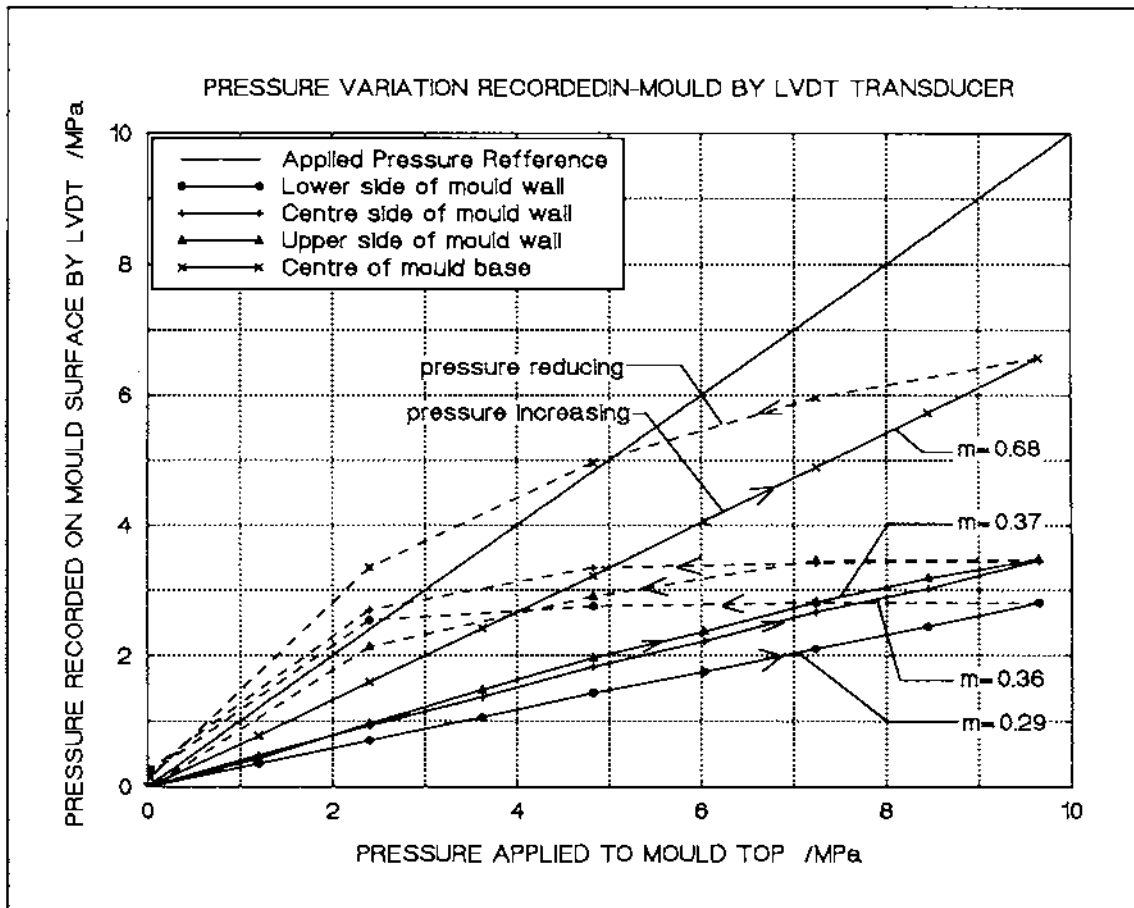

**Figure 5.1a** Compaction pressure plotted against transmitted pressure

static process). Pressure recorded on the block wall is plotted against pressure on the mould top (applied pressure calculated from the applied force and the known area of the mould surface). Only one transducer was initially used and hence the traces in figure 5.1a are actually the amalgamation of six separate block pressings, each trace being the average of two presses.

The maximum pressure readings agreed surprisingly well between pairs of blocks, averaging an agreement within  $\pm 0.25$  MPa ( $\pm 4\%$  for base pressure). The applied pressure plot has been included in the figures for ease of comparison and plots as a straight line with a maximum of 9.66MPa (40 tonnes applied to the largest block face). In general the internal pressure throughout the mould increases linearly with the applied pressure but with differing rates of gain around the block (Table 5.1).

The transducer on the mould base recorded the highest pressure gain of 68%, rising to a maximum of 6.7 MPa compared to the applied 9.7 MPa, a loss of 3 MPa.

The transducers located at the upper and central regions of the mould-side wall both gave recorded maximum pressures of 3.5MPa (3.5 for the upper region and 3.48MPa for the central region i.e gain = 37% and 36% respectively). The pressure

distribution along the length of the block at mid-height was also recorded. The pressure recorded at one third the length along the mould side wall was also 3.5 MPa (gain = 37%), while the pressure recorded at the end of the mould wall was 3.9 MPa (gain = 40%), slightly higher than at the centre.

The lower centre side wall transducer recorded a maximum pressure of 2.8MPa.

**Table 5.1** Average Transmitted Pressure Recorded by LVDTs

| Location of LVDT | Average Max Pressure /MPa | 95% Confidence bounds | Pressure Gain % |
|------------------|---------------------------|-----------------------|-----------------|
| Base             | 6.67                      | 6.40..6.94            | 68              |
| Upper Side       | 3.50                      | N/A                   | 37              |
| Centre Side      | 3.48                      | 3.14..3.83            | 36              |
| Lower Side       | 2.80                      | 2.75..2.86            | 29              |

If the increase in pressure in the upper region of the mould wall (Fig 5.1a) is examined, it can be seen that this rise decreases slightly with increasing applied pressure and may be tending towards a maximum. This trend is not apparent for the remaining traces.

This pattern does not fit any obvious simple model and the only firm conclusion which may be drawn is that the soil condition is far from a simple hydrostatic fluid model.

The pattern of quasi-static pressure reduction was also recorded. The mould base pressure begins to drop off as soon as the applied pressure is reduced and continues to reduce at an increasing rate. At approximately 5MPa the base pressure is the same as the applied pressure. Below 5MPa the base pressure continues to decrease but remains higher than the reducing applied pressure.

The mould wall pressures also fall back as log curves. There is a lag period between when the applied pressure is reduced and when the mould wall pressures begin to drop significantly. This lag is least for the upper regions of the mould and increases for the central and lower regions respectively.

The material inside the mould under full (9.7MPa) compression will have undergone both plastic and elastic deformation. Large plastic deformation is evident from the significant volume reduction, typically 1.5:1. Elastic deformation is also apparent, although less pronounced, by the

increase in block height as the applied load is removed (see Fig 5.1b, block height during compaction).

The pattern of mould pressure fall may indicate a pattern of vertical and horizontal stress reduction. As the applied pressure is reduced so those regions of the block nearest to the moving piston begin to decompress. In the upper regions of the block this decompression takes place initially in the vertical direction, the direction of movement. The resulting elastic expansion of the material is largely vertical as the mould maintains a lateral constraint. The vertical expansion reduces the lateral stress which is being applied to the mould-side walls, according to a poisson-type relation. As the upper lateral stress reduces so does the frictional shear stress with the mould wall. The reduction in mould wall shear stress effectively reduces the vertical constraining force, allowing the lower regions of the block to decompress. As the applied pressure is reduced further so the region of elastic expansion moves downward.

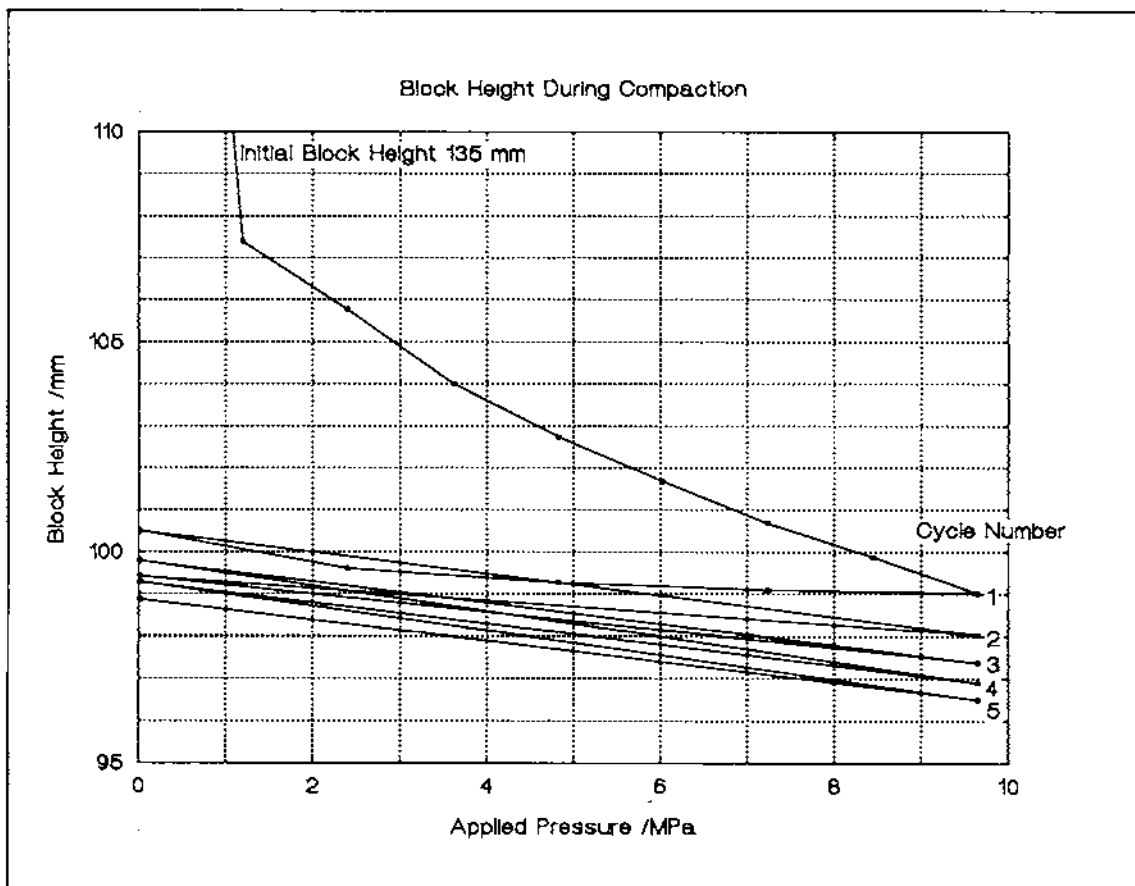

Figure 5.1b Block height during compaction.

The upper region of the block, being the nearest to the moving piston during compaction, would be expected to be in the most stressed/compacted state (closest to a hydrostatic condition). Therefore it could be assumed that this region would exhibit the largest elastic recovery and consequently the most

rapid rate of reduction in side wall pressure. The central region of the block would be in a similar condition but could not begin to significantly decompress until the upper layer's vertical restraining influence had diminished sufficiently. This would then result in an effective lag in lateral decompression which would increase with distance from the moving piston i.e. towards the lower regions. Fig 5.1a (above) illustrates this progressive decompression. If the lateral and base pressures are examined at an applied pressure of 2.4MPa, it can be seen that the base pressure is the largest, greater than that applied but reducing the most rapidly. The upper region transducer shows that the lateral pressure in this band is the lowest and reducing quickly but not as fast as the base pressure. The central region has just begun to decompress significantly but remains higher than either the lower or upper regions and the lowest region is yet to begin dropping significantly.

In summary, as the applied pressure is raised to a maximum of 9.7MPa, the base pressure as recorded by the LVDT rises to 68% of this value and the mould side pressures to only 37%, 36% and 29% (upper, central and lower regions of the block respectively). On compression the bottom and side pressures rise linearly with applied (top) pressure. On decompression however, they fall back more slowly than the applied pressure, showing a strong hysteresis pattern.

## 5.2 DOUBLE-SIDED COMPACTION

There are various ways of applying "double-sided" pressure. The one used here was to fix the base plate, move the top plate (piston) and to let the sidewalls of the mould "float". An exact equality of top and bottom pressures was not achieved, as it might have been with mechanically linked top and bottom pistons. Perfect double-sided compression might have raised the sidewall pressure a little higher, probably to about 50% of the applied piston pressure.

The plot of applied pressure against recorded pressure is shown as Fig 5.2. The arrangement of the double sided compaction rig was such that only the central side wall and base pressures were recorded. Both of the recorded pressures were seen to be significantly higher than for single sided, 7.9MPa and 4.4.Mpa for the base and centre-side respectively. This represents a 12% increase in mould base pressure and a 9% increase in mould sidewall pressure (to 81% and 45% respectively).

This would appear to clearly indicate that double sided compaction was more effective in compressing the block. However, although significant in terms of pressure transmission for a high internal friction mix (no cement) when 5% cement was added to the mix, the pressure difference between single sided and double sided reduced to 10% and 5% for base and centre respectively.

Furthermore, when these blocks were tested for wet compressive strength after seven days of damp curing, the single

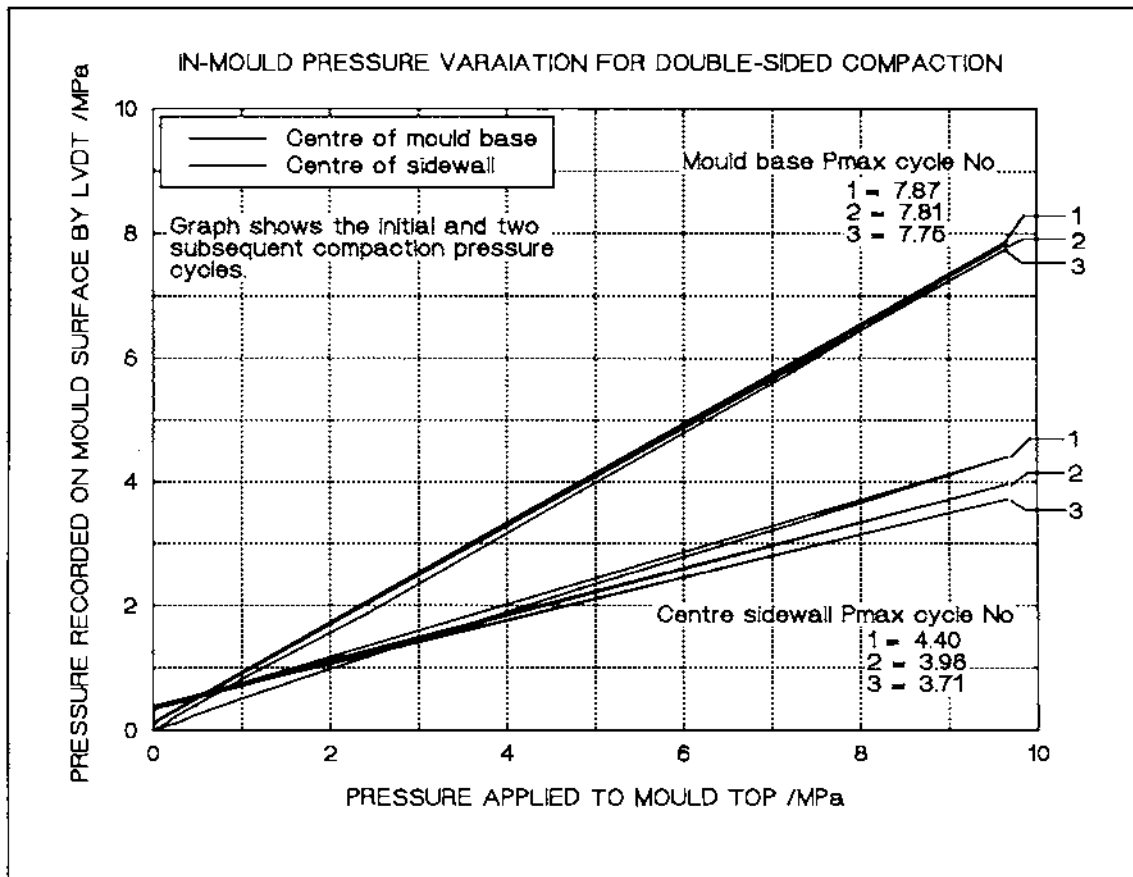

**Figure 5.2a** Pressure transmission for double-sided compaction

sided ones gave an average of 2.84 MPa (std 0.076) while the double sided ones gave an average of 3.03 MPa (std 0.087). This represents only a 7% increase in wet compressive strength, although this difference is likely to increase marginally with additional curing time.

Having initially stated that by using a soil mix without cement the internal friction would be higher, the difference between the above cases with and without cement should be expected. The apparently large increase in transmitted pressure for the no-cement blocks translates into only a small increase for the cement blocks.

If it is assumed that density is proportional to strength as has been suggested by other authors (Ingles & Metcalf, 1972, Ref No.10 & Webb, 1991, Ref No.20) then it might be expected that double sided compaction would produce a more uniform internal density distribution. If the compacted sintered bearing is taken as an example; single sided compaction produces a compact which is demonstrably more dense in the region nearest to the compacting piston. When compaction is double-sided the compact density is improved throughout but with a reduced improvement in the central region. If this is related to stabilised block strength then this would suggest that double-sided compaction should produce blocks which have more uniform internal density



distribution and hence a more uniform strength distribution through their height.

Double sided compaction is more effective than single sided compaction which is clearly shown by the increase in both base and mould wall pressures. However, this increase only results in a 7% increase in seven day wet strength. As such the additional mechanical complexity and associated cost required to produce a commercial double sided block press would appear unwarranted.

### **5.3 REDUCTION IN MOULD WALL FRICTION**

The effect of reducing mould wall friction was examined by lining the mould with a twin thickness of plastic sheeting, separated by a lubricating oil film. Figure 5.3 shows the plot of applied pressure against the recorded pressures. Lining the mould with plastic was used as an experimental technique to assess the effect of mould wall friction and would not be recommended for field use. During compaction the inner layer of plastic was dragged down with the compacting soil and forced to ruck into the body of the block thus producing flawed blocks. However, this should not invalidate the pressure transmission data gathered.

Both the base pressure and all of the recorded mould wall pressure were seen to rise significantly compared with the much rougher datum model. The base pressure rose to 7.6MPa whilst the upper and lower mould wall regions rose to 4.1 and 3.6 MPa respectively. This represents a 13% increase in base pressure and a 17% and 29% increase in upper and lower pressures. Again it would be expected that this would translate into a reduced effect in the final wet strength of the blocks but it does show that mould wall friction plays an important role in determining the effectiveness of the applied pressure in block compaction. It would be recommended that the mould should be as smooth as possible and that any machining marks etc should be orientated in the direction of the soil material movement during compaction i.e. perpendicular to the compaction piston.

### **5.4 MOULD WALL TAPER**

Mould wall taper was investigated by angling the mould side walls to 1° and 5° from the vertical. This was done by separating the mould walls and bolting them in place with tapering sets of shim steel to produce the desired angles. The mould was arranged such that compaction was from the larger side of the taper. Figure 5.4 shows the plot of applied pressure against recorded pressure. The base pressure was seen to rise slightly to 6.9MPa but this was believed to be a function of the experimental method. The same dry mass of soil was used to produce each block throughout the set of tests and as a result

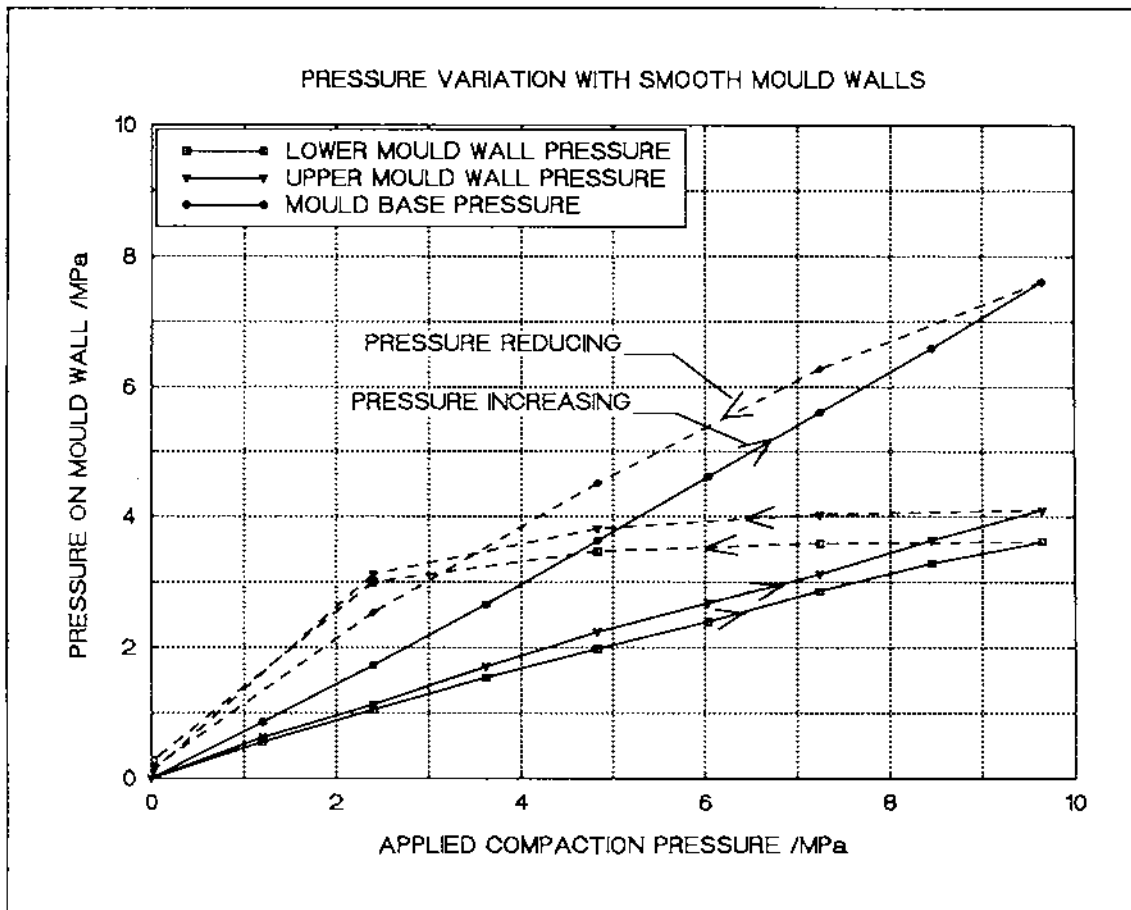

Figure 5.3 Pressure transmission with smooth mould walls

of the manner in which the mould was tapered, the final block height was reduced. Therefore some increase in base pressure would be expected as the height through which the applied pressure was acting was reduced. The mould side wall pressures were also recorded. The upper region pressure was significantly lower than that for the standard mould configuration but this was again a result of the manner in which the mould was tapered, the reduced block height and increased separation between the compacting piston and the mould wall effectively placed the upper transducer above the top of the block. The central and lower region pressure were slightly increased at 4.2 and 2.9MPa but not above what might be expected as a result of the increase in projected area seen by the compacting material. The 5° taper mould produced similar results; the base pressure increased to 7.5MPa while the central pressure increased to 4.4MPa.

In conclusion, mould taper does not have any apparent beneficial effect on pressure transmission. The block ejection cycle however required much lower forces which had to be sustained for a much shorter period of time. Taper may be used to ease ejection but the somewhat awkward shape of the blocks does not seem to justify the improved ease of ejection. Taper would not be recommended for incorporation into block production machines.

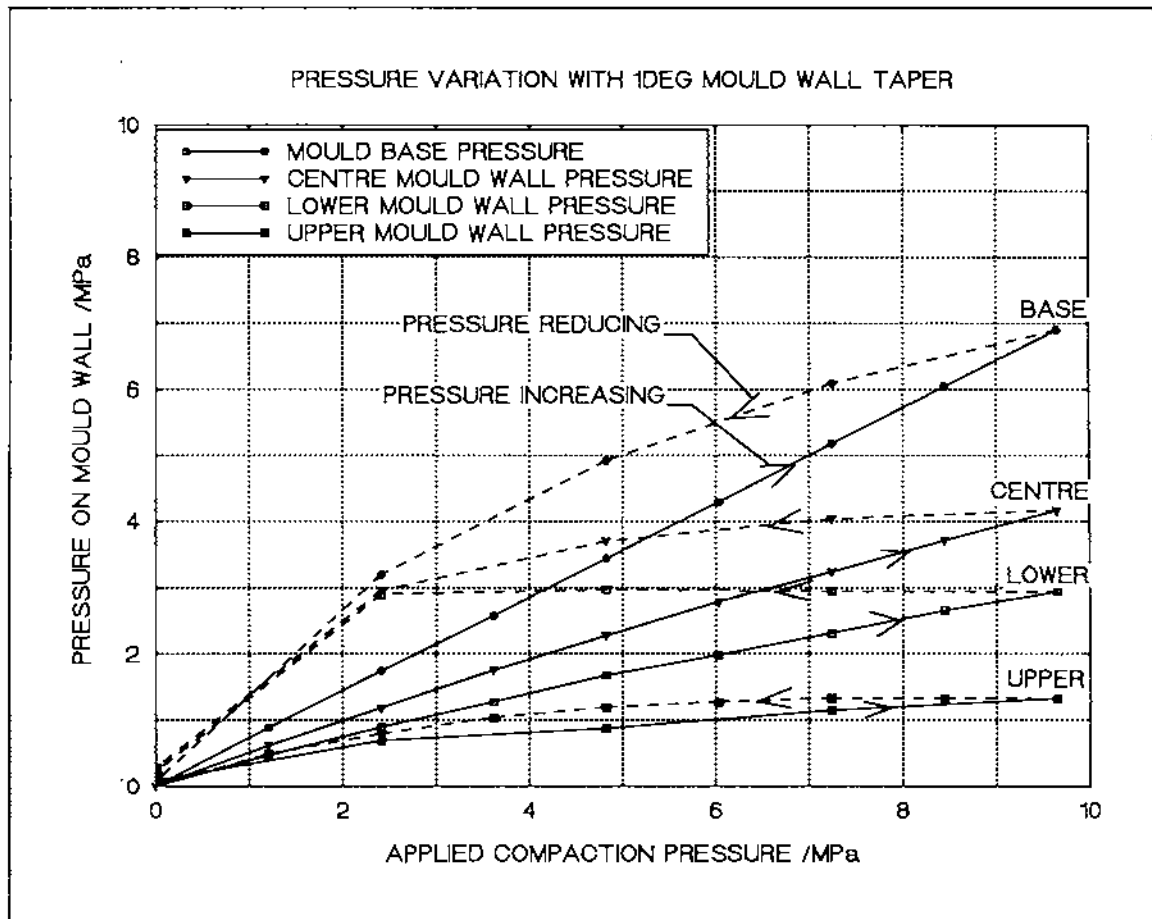

Figure 5.4 Pressure transmission with 1° mould wall taper

### 5.5 PRESSURE CYCLING

Here the term pressure cycling is used to imply the decompression of a fully compacted block to various levels of pressure and the subsequent recompression back to the original fully compacted applied pressure.

The manner in which a soil block would respond to applied pressure cycling was unclear. Three possible effects were expected prior to experimentation. The cycling would have no effect on the transmitted pressure, the transducers recording the same value of pressure as that recorded for the initial cycle. The cycling would progressively increase the transmitted pressure to a limiting maximum, independent of the magnitude of the cycle. The cycling would increase the transmitted pressure to a limiting maximum value depending on the magnitude of the cycle.

**Table 5.5a** Pressure transmission on full-pressure cycling

| Cycle No | Maximum applied pressure /MPa | Maximum mould base pressure /MPa | Maximum upper mould wall pressure /MPa | Maximum centre mould wall pressure /MPa | Maximum lower mould wall pressure /MPa |
|----------|-------------------------------|----------------------------------|--|---|--|
| 1        | 9.65                          | 6.72                             | 3.48                                   | 3.55                                    | 2.84                                   |
| 2        | 9.65                          | 6.85                             | 2.55                                   | 3.38                                    | 2.26                                   |
| 3        | 9.65                          | 6.93                             | 2.14                                   | 3.20                                    | 2.04                                   |
| 4        | 9.65                          | 6.92                             | 1.87                                   | 3.18                                    | 1.89                                   |
| 5        | 9.65                          | 6.92                             | 1.69                                   | 3.13                                    | 1.81                                   |

Table 5.5a shows the pattern of pressure change in the mould side wall for cycling from 9.7 to 0.1 MPa for standard single sided compaction. It can be seen that the base pressure remains almost constant, in general rising slightly with successive cycles but not significantly (the LVDT hysteresis will account for an increase of 0.1MPa per cycle when cycling from 0 to 7 MPa). The mould side wall pressure appears to drop significantly with each cycle, dropping less with successive cycles.

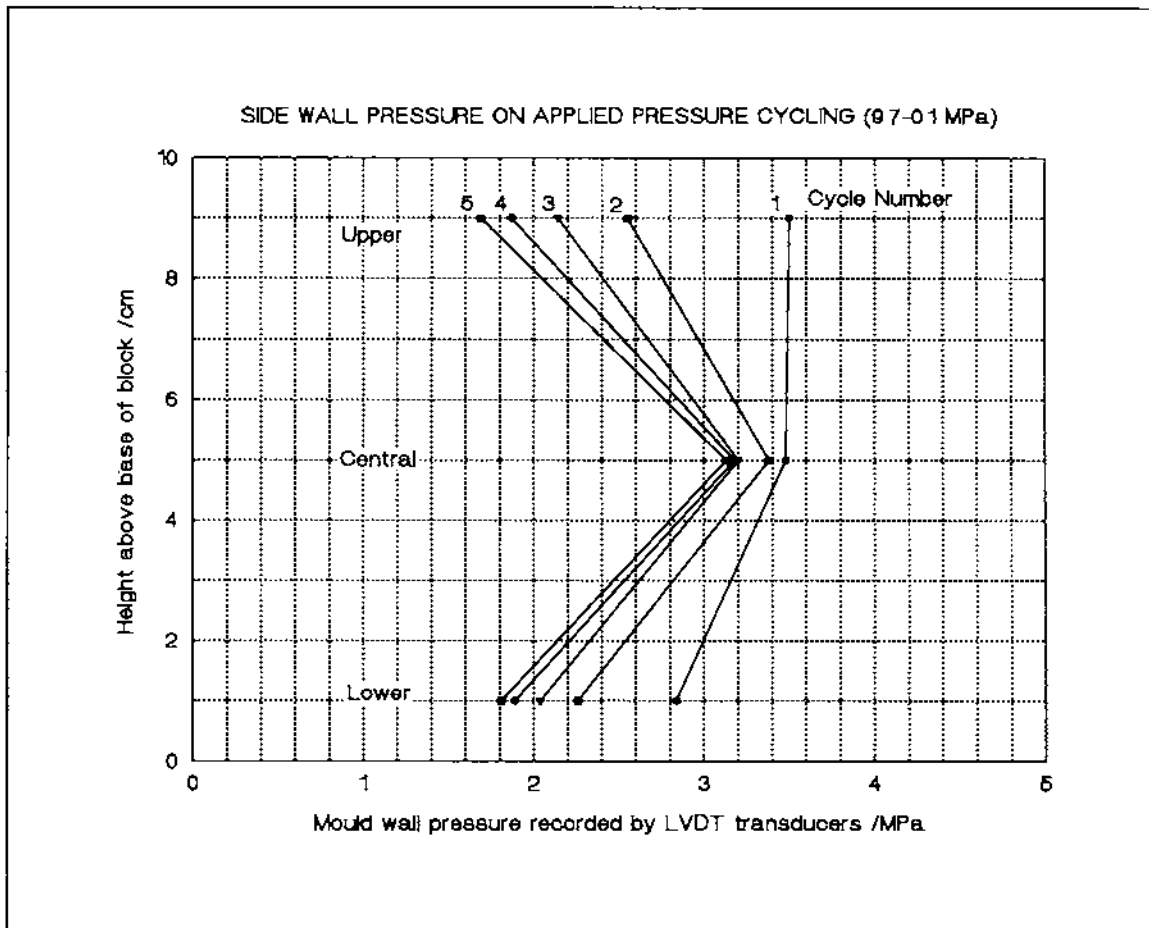

**Figure 5.5a** Recorded pressure on mould walls (upper, central and lower regions) with successive pressure cycles

Figure 5.5a shows the pattern of pressure reduction with successive cycles plotted with height of the transducer from the base of the block. This appears to indicate that the cycling action reduces the upper and lower side wall pressure at a greater rate than that for the central region. It might be argued that the reduction in upper side wall pressure is a result of the reduction in block height (see below). However, the reduction in the central and lower regions could not be accounted for on this basis.

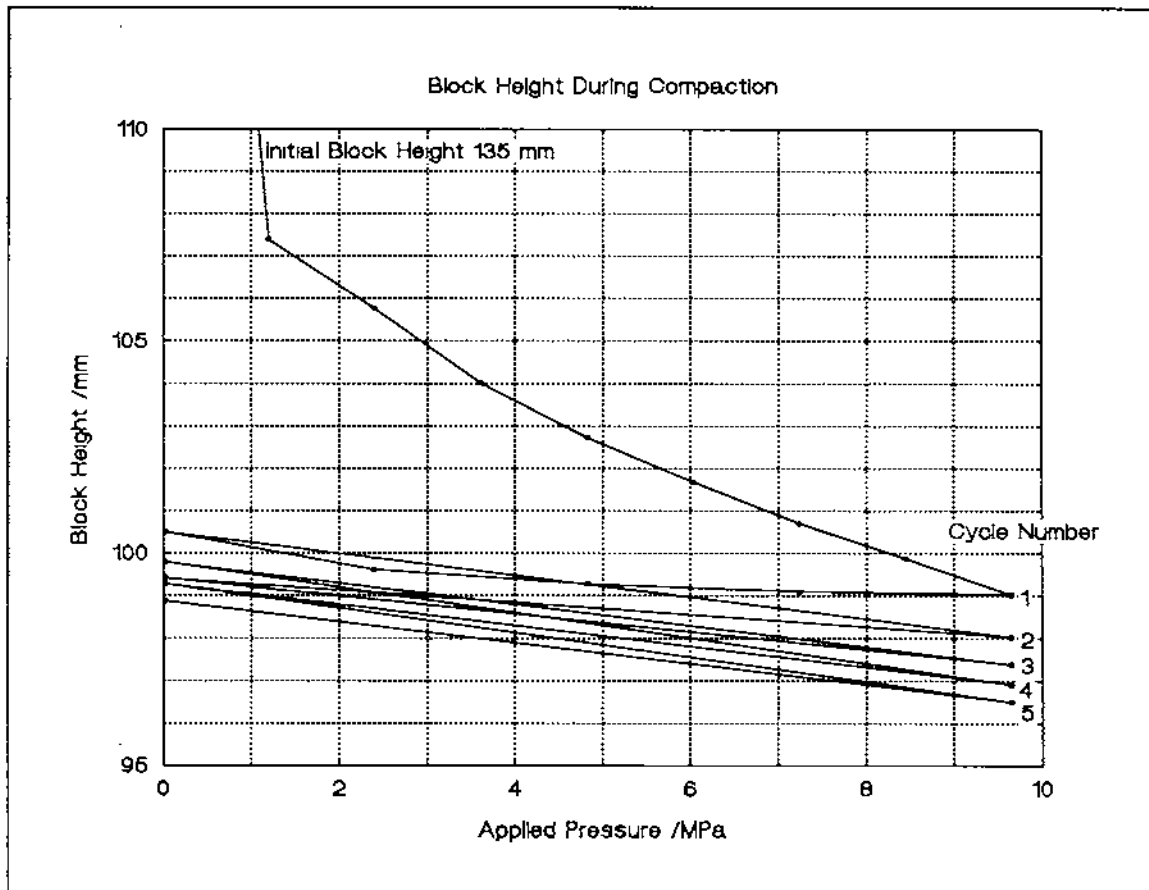

**Figure 5.5b** Block height during compaction and decompression.

If Figure 5.5b is examined then it can be seen that the block height reduces to 96.5 mm under full pressure after 5 cycles. The upper transducer's centre line is 90 mm above the base of the block and the active face is 5mm in radius. The transducer is therefore recording the upper side wall pressure from 3.9-13.9 mm below the upper surface for the first cycle and from 1.5-11.5 mm below the surface for the fifth cycle. The pressure reduction might then be accounted for if it is assumed that the edge region of the compaction piston is at atmospheric pressure (0 MPa on the LVDT scale) and that a region of transition from 0 to 3.5 MPa (max side wall pressure on the first cycle) exists. As the upper face of the block moves downward approaching the upper LVDT then it might be expected that the recorded pressure would drop. However without including a pore pressure type concept, it appears more difficult to explain the fall in the lower side wall pressure. No satisfactory explanation has yet been formulated.

Partial pressure cycling (cycling from full compaction pressure to a lesser pressure greater than zero) is shown as Figure 5.5c. Table 5.5b shows the numerical values for the maximum and minimum cycled pressure values for each cycle. This plot of applied pressure against recorded pressure is from one of the blocks which were used to determine the effect

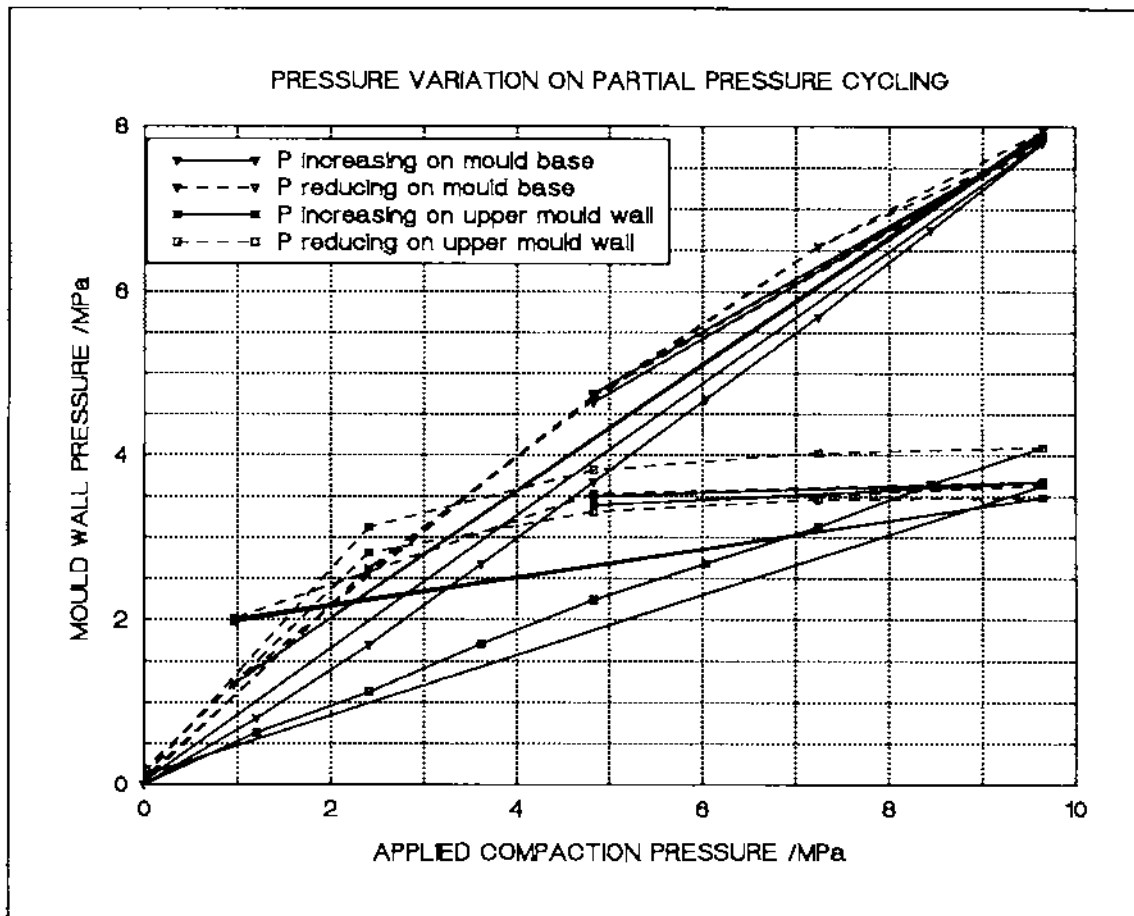

Figure 5.5c Pressure variation on partial pressure cycling

Table 5.5b Pressure values relating to figure 5.5c

| Cycle No | Applied pressure /MPa | Mould base pressure /MPa | upper mould wall pressure /MPa |
|----------|-----------------------|--------------------------|--------------------------------|
| 1        | 0.00 → 9.66           | 0.00 → 7.80              | 0.00 → 4.10                    |
| 2        | 0.20 → 9.66           | 0.05 → 7.82              | 0.12 → 3.63                    |
| 3        | 4.83 → 9.66           | 4.64 → 7.86              | 3.39 → 3.67                    |
| 4        | 4.83 → 9.66           | 4.75 → 7.87              | 3.49 → 3.68                    |
| 5        | 0.97 → 9.66           | 1.22 → 7.91              | 2.01 → 3.48                    |
| 6        | 0.97 → 9.66           | 1.22 → 7.95              | 1.97 → 3.48                    |
| End      | 0.02                  | 0.10                     | 0.19                           |

of reduced friction but this trace shows the effect of residual wall shear forces well. The block was initially compacted to 10 MPa and then cycled down to 0.1MPa. On repressurising the mould wall side pressure dropped significantly. The block was then cycled from full pressure to half pressure twice and showed no

This appears to suggest that pressure cycling has little or no effect on a region unless the pressure is dropped back to significantly less than the lag period pressure mentioned above (section 5.1).

### 5.6 Summary

From the work outlined above it may be concluded that the internal compaction state of the soil material within the mould is not hydrostatic. It would appear unlikely that the side mould walls, under datum conditions, will ever exceed 50% of the applied pressure and normally be less than 40%. This being the case, significant material savings in mould wall thickness would appear possible. A significant reduction in the pressure applied to the compacting piston is apparent in the base plate which may be assumed to be indicative of internal shear and inter-particle, particle-mould-wall friction. The mould wall shear is significant and may be reduced by smoothing/lubricating the mould walls. Taper has little or no beneficial effect on the compaction process but does reduce the ejection load and the time for which the load must be applied. Double sided compaction does have a significant beneficial effect on compaction but this benefit would be small compared to the cost of the extra mechanical complexity entailed.



## 6. THE PRESSURE-CEMENT-COMPRESSIVE STRENGTH RELATION

### 6.1 INTRODUCTION

The compaction pressure and the cement content used in the manufacture of stabilised soil blocks are, for a given soil, the prime determinants of the block's final cured strength. Compaction pressure and cement content may be traded against each other for a given final cured strength. The compaction pressure used in field production will depend on the type of compaction machinery selected at the project outset and so may be considered a capital cost for the process while the cement content used may be considered a running cost. As high pressure compaction machines are more expensive to purchase than low pressure machines it is useful to examine the relative effect of both compaction pressure and cement content on cured strength.

M.G.Lunt of the UK Building Research Establishment (Building Research Establishment, 1980, Ref No.4) conducted a series of tests on two Ghanaian soils (both with high fines content, 49.0 and 56.0%) to assess the effect of increased compaction pressure on the blocks' performance when stabilised with 6% lime by dry weight. He concluded that "Improved performance can be achieved by increasing the compaction pressure although the degree of improvement diminishes as this pressure is increased. It is suggested that presses operating in the range 8 to 16 MPa could give satisfactory and economical results." This work thus suggests that there may be some economic advantage in using a high pressure compaction machine. However, increasing the compaction pressure is only one way to improve the final compressive strength of a block. Although it is generally accepted that the performance of a block will be improved both by raising the compaction pressure and by increasing the stabiliser content, the relative effect of these two changes appears to be uncharted. For example, does a doubling of compaction pressure give the same improvement in strength as a doubling of cement content? The following section examines the effect of both compaction pressure and stabiliser (cement) content on the final (seven day) wet compressive strength of the soil-A used for the above tests.

### 6.2 EXPERIMENTAL INVESTIGATION

A number of soil-cement cylinders were produced for a range of compaction pressures from 1 to 10 MPa and a range of cement contents from 3% to 11%. For each combination of pressure and cement three cylinders were produced, the average value of the wet compressive (seven day) strength was used in subsequent comparisons. The soil-A used is described in appendix B. This soil was selected as one which should be suitable for stabilisation based on previous authors' reports (United Nations, 1964, Ref No.17). Although the numerical values given below are

unlikely to be correct for other soil types, it is expected that the trends exhibited will be, provided that the other soils fall within the range of suitable soils as defined in DTU Working Paper No.38.

The mould used was that specified in BS1924 (British Standards Institution, 1975, Ref No.3). A constant water content of 8% was used throughout the set of experiments<sup>1</sup>. The mould was filled with a constant mass ( $\pm 0.2\%$ ) of stabilised mixture regardless of the cement content. The cylinders produced were between 110mm and 125mm high, depending on the compaction pressure used, each having a nominal diameter of 50mm. The compacted green cylinders were sealed inside plastic bags in a damp atmosphere in batches of three and left to cure for seven days before complete immersion in water prior to wet compressive strength testing.

The results of the testing showed that both an increase in cement and an increase in compaction pressure increases the seven day wet strength, however the relative influence of each is different. Figure 6.3a and 6.4a respectively show the rate of gain in strength when either cement or compaction pressure is held constant. On each graph the data points connected by dashed lines are the average of three experimental results. The error bars associated with the data points represent a statistical confidence level of 90%, the length of the bars giving an indication of the scatter in results.

In order to relate cement percentage and compaction pressure, the raw experimental data (compaction pressure, cement percent and cured strength) was used as the input for a PC-based modelling package SPSS. A number of models were tried of which a natural log against natural log type plot was found to be the best. The solid lines on the figures given below represent the best fit to the data generated by SPSS;

$$\ln(\text{str}) = (0.315 \times \ln(\text{pr})) + (1.216 \times \ln(\text{cem})) - 2.178)$$

Where;     str = compressive strength in MPa  
          pr  = compaction pressure in MPa  
          cem = cement content percentage.

This model gave an adjusted R square measure of fit of 98.2% (Multiple R 99.1%)

---

<sup>1</sup> The optimum water content at the time of compaction should strictly have been found for each compaction pressure and cement content. However the soil-A used has a low sensitivity to moisture content and as such the effect on the experimental data should be minimal.

### 6.3 THE EFFECT OF COMPACTION PRESSURE AND ENERGY ON SEVEN DAY WET STRENGTH

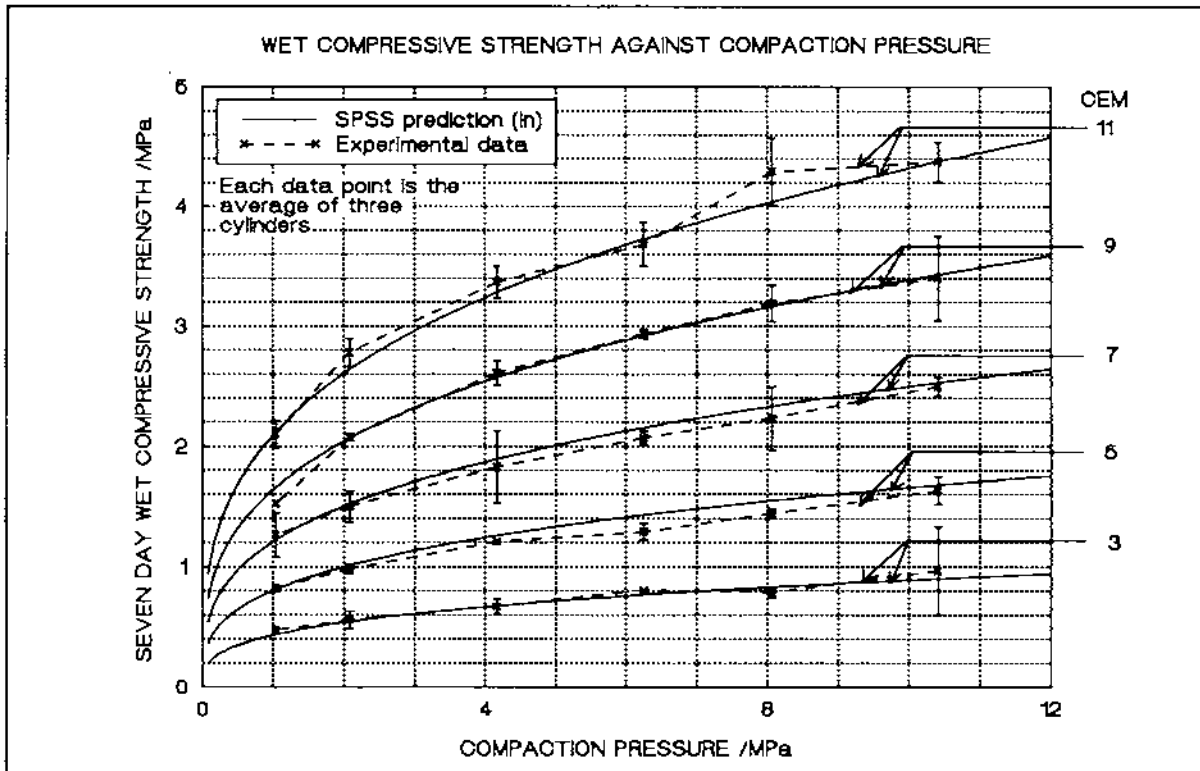

**Figure 6.3a** The effect of increasing compaction pressure on seven day wet compressive strength

For a given cement content (Fig 6.3a) strength increases with increased compaction pressure. Below 2 MPa this increase is rapid while above this the rate of increase reduces, tending towards a maximum strength as previously reported by Lunt (in Building Research Establishment, 1980, Ref No.4). Table 6.5 (below) shows the effect of doubling compaction pressure on the wet compressive strength. The figure given is the fractional increase in absolute strength resulting from doubling the respective variable. It can be seen that although the absolute rate of gain in strength is higher for high cement contents, the fractional increase in strength is fairly constant. A doubling of compaction pressure results in roughly 23% increase in wet compressive strength throughout the range.

Figure 6.3a shows that a given change in the compaction pressure of low pressure machines will have a large effect on the cured strength. A poorly operated or poorly maintained Cinva Ram may only operate at 1MPa, instead of the 2MPa usually quoted. This would result in a cured block strength 25% lower than that for a well operated/maintained machine.

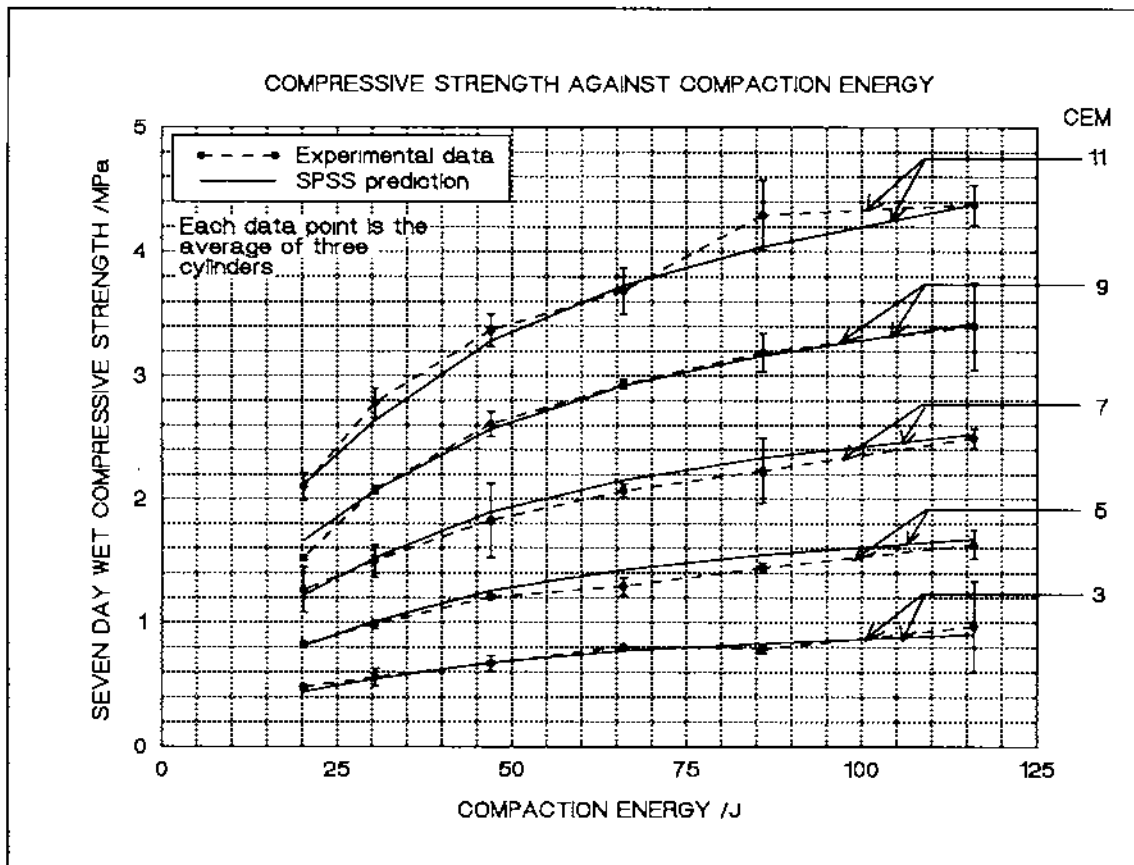

**Figure 6.3b** The effect of compaction energy on seven day wet compressive strength

Figure 6.3b is a plot of compressive strength against compaction energy. This graph is similar to 6.3a but shows the compaction process in terms of the energy expended in compacting the samples<sup>2</sup>. If the 3% cement trace is examined then it can be seen that by doubling the compaction energy from 25 to 50J the compressive strength increases by 37%, but doubling the energy from 50J to 100J only increased it by 22.9%. This is in keeping with the results shown in figure-6.3a as the energy required to increase the compaction pressure one unit is greater at higher pressures than at lower ones and hence the diminishing return.

<sup>2</sup>. The energy values are based on those found when quasi-statically compacting full-size blocks and were not directly recorded for the cylinders.

## 6.4 THE EFFECT OF CEMENT CONTENT ON SEVEN DAY WET STRENGTH

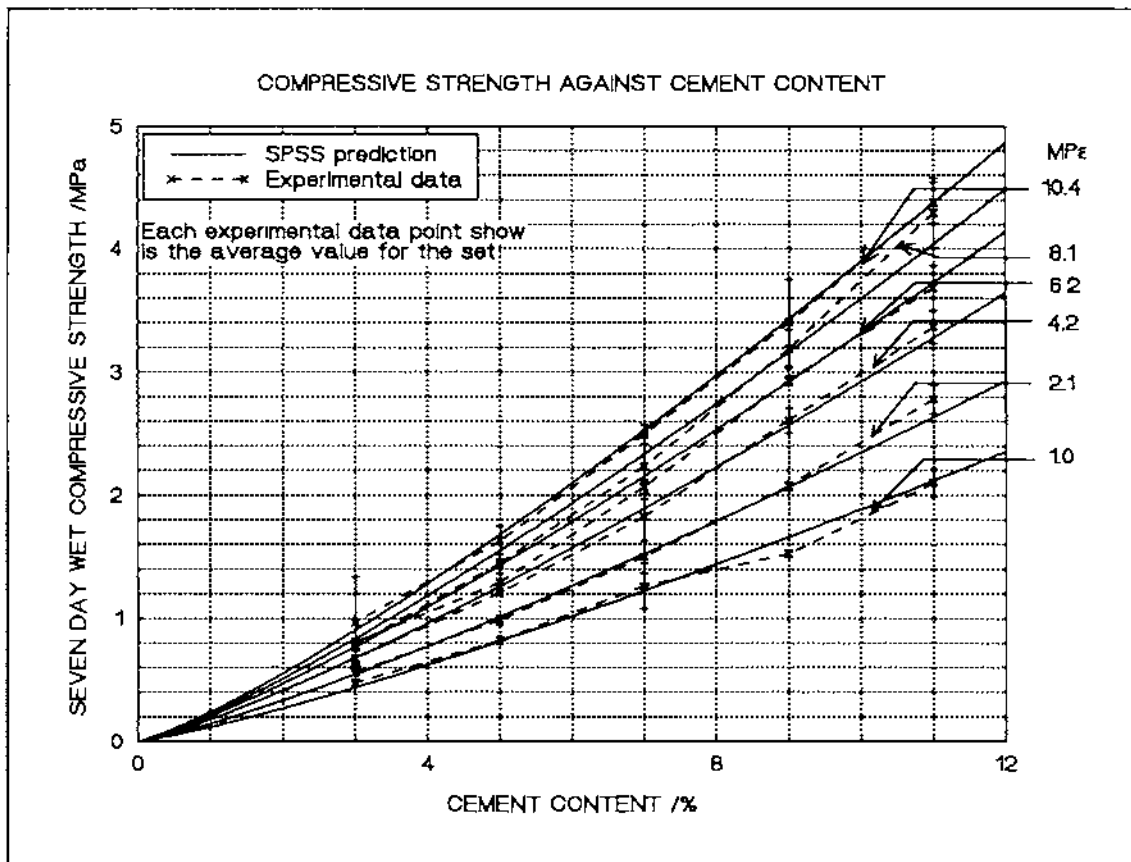
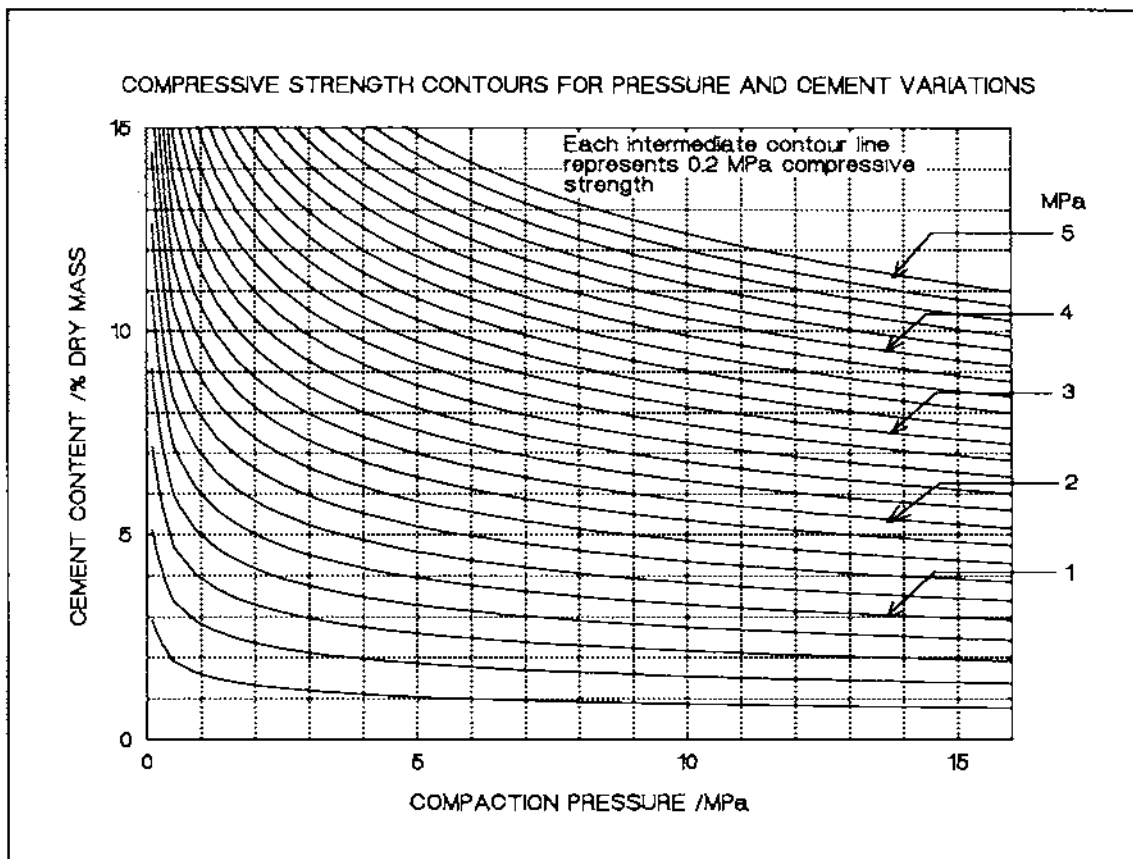

Figure 6.4a The effect of cement content on seven day wet compressive strength

If figure 6.4a is examined it can be seen that for a given pressure the rate of increase in absolute strength increases with increasing cement content. However, if table 6.5 (below) is examined it can be seen that the fractional increase in strength remains approximately the same, reducing slightly at higher cement contents. A doubling of cement content from 3 to 6% at a compaction pressure of 1.0 MPa produces a strength increase of 140% while a doubling of cement from 6 to 12<sup>3</sup>% produces an increase of 133%.

<sup>3</sup> The values for 12% cement used here are based on the SPSS model and represent an extrapolation above the maximum experimental value of 11%.

## 6.5 THE PRESSURE-CEMENT-STRENGTH RELATIONSHIP



**Figure 6.5a** A contour plot relating compressive strength to cement content and compaction pressure

Figure 6.5a and 6.5b show the combined picture. Figure 6.5a is a contour plot showing lines of constant wet strength in relation to cement content and compaction pressure. Figure 6.5b is a three dimensional representation of the strength equation produced by SPSS from the experimental data. It can be seen from these figures that increasing the cement content of a stabilised block will in general provide a more effective method of increasing strength than increasing compaction pressure. Two standard wet strength values are normally quoted, either 1.4 MPa (Fitzmaurice 1958) or 2.8MPa (Webb 1988)<sup>4</sup>. The relative effect of cement and compaction pressure may be examined by regarding the reduction in cement content required when changing production from a 2MPa compaction machine to a 10 MPa machine at each of these two strength standards. Figure 6.5a shows that for a wet strength of 1.4 MPa and a compaction pressure of 2 MPa a cement

---

<sup>4</sup> Strength standards for soil-cement blocks are now becoming more widespread and vary from country to country to reflect the differing climates.

content of 6.6% would be required, while for a compaction pressure of 10MPa a cement content of 4.3% would be needed. In effect, for this soil, increasing the compaction pressure five times produces only a 35% reduction in cement demand. If the 2.8 MPa strength standard is considered, the same five fold increase in compaction pressure again results in a cement saving of only 35%.

**Table 6.5** The relative effects of pressure and cement

| Doubled Parameter                                  | Strength Increase<br>Compaction 2 → 4 MPa<br>Energy 25 → 50 J<br>Cement 3 → 6 % | Strength Increase<br>Compaction 4 → 8 MPa<br>Energy 50 → 100 J<br>Cement 6 → 12 % |
|--|---|---|
| Compaction (11%cem)<br>Pressure<br>Doubled (3%cem) | 2.59 → 3.23 MPa<br>+ 24.7%<br><br>0.54 → 0.67 MPa<br>+ 24.1%                    | 3.23 → 4.03 MPa<br>+ 24.7%<br><br>0.67 → 0.82 MPa<br>+ 22.4%                      |
| Compaction (11%cem)<br>Energy<br>Doubled (3%cem)   | 2.38 → 3.35 MPa<br>+ 40.7%<br><br>0.49 → 0.70 MPa<br>+ 37.0%                    | 3.35 → 4.20 MPa<br>+ 25.0%<br><br>0.70 → 0.86 MPa<br>+ 22.9%                      |
| Cement (10.4MPa)<br>Content<br>Doubled (1.0MPa)    | 0.90 → 2.10 MPa<br>+ 133.3%<br><br>0.42 → 1.01 MPa<br>+ 140.5%                  | 2.10 → 4.89 MPa<br>+ 132.9%<br><br>1.01 → 2.35 MPa<br>+ 132.7%                    |

The trend which emerges from this study is that the final wet strength achieved by the block is much more sensitive to changes in the cement content than in the compaction pressure. By increasing the compaction pressure 400% the cement saving resulting is 35%. In order to interpret these figures, a simple economic model was constructed to compare the cost effectiveness of a 2MPa Cinva Ram and a 10MPa Brepack when producing blocks of 1.4 and 2.8 MPa wet compressive strength. This model is presented in the following section, 6.6.

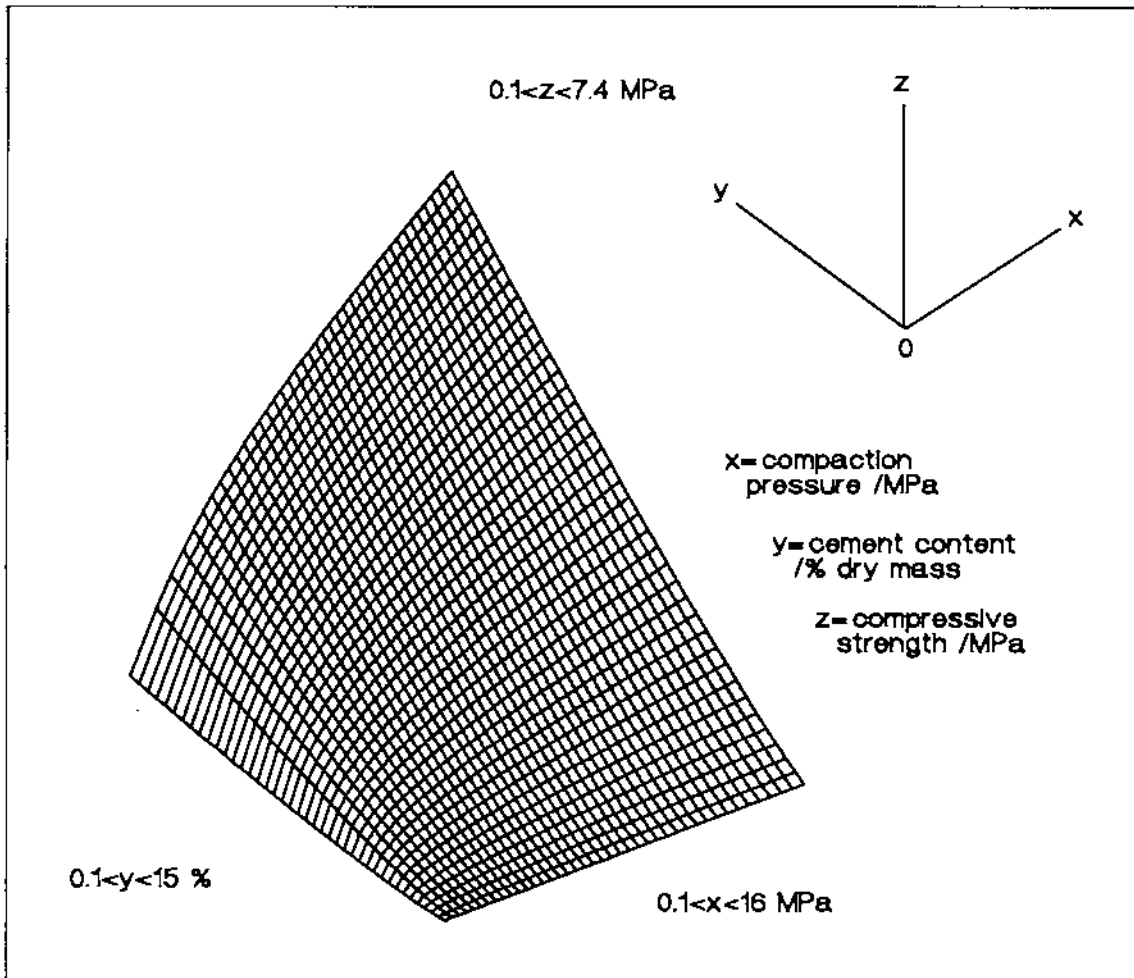

**Figure 6.5b** A three dimensional representation of the relationship between compaction pressure, cement content and compressive strength

#### 6.6 SIMPLE ECONOMIC COMPARISON BETWEEN MACHINES GIVING RESPECTIVELY 2 AND 10MPa COMPACTION

The following model uses the 2MPa compaction pressure Cinva Ram and 10MPa Brepack machines for comparison. Two comparisons are made, one for blocks of 1.4 MPa wet compressive strength and one for blocks having 2.8MPa wet compressive strength.

It is assumed that both machines are operating in the same country with the same cost for cement and labour; £3.00 per 50 kg bag and £3.50 per man day (the costs quoted are those for Sri Lanka in 1993). Both machines use the same soil-A, as used in the above experimentation, compacted at 8% water content, both produce blocks of 290x140x100mm.

Both of the machines are manually operated toggle lever mechanisms. The Brepack generates higher pressure by the incorporation of a hydraulic ram which is operated after initial



compaction by toggle lever has occurred. As large variations in the actual and quoted production outputs of each of these machines is common (production output depends heavily on the experience and dedication of the operators), it has been assumed that the maximum Cinva Ram output, quoted by the machine manufacturers, of 300 blocks per 8 hour day will be achieved and will be taken as the datum from which to extrapolate a comparable production figure for the Brepack. The maximum Cinva Ram production rate equates to the production of one block every 96 seconds. It will be assumed that the additional time taken to operate the Brepack hydraulic system is 20 seconds giving the Brepack a production rate of one block every 116 seconds or 248 blocks per 8 hour day.

The labour requirement for the Brepack may also be based on that for the Cinva Ram. The machines produce different numbers of blocks of different density; 300 blocks per day (see above) of 1980 kg/m<sup>3</sup> for the Cinva and 248 blocks per day of 2130 kg/m<sup>3</sup> for the Brepack. Hence the labour required, per day or per block, for soil winning and block compaction is different. If the labour distribution shown below is assumed for the Cinva Ram when producing blocks of 1.4 MPa wet compressive strength (requiring 2,084.4 kg of soil per 300 blocks) then soil winning/processing labour costs may be calculated per kg of soil required. Similarly the labour cost of compaction and stacking may be calculated per block, 16 man hours are required to compact 300 Cinva Ram blocks (a labour cost of £0.023 per block) while 16 man hours are required to produce 248 Brepack blocks (£0.028 per block).

It is assumed that the soil used is free and the only cost is then the cost of winning which is included in the labour cost.

It is assumed that the working life of a Cinva Ram is 3 years at full production resulting in 270,000 blocks when working for 6 days per week and 50 weeks per year. The life of the Brepack is also assumed to be 270,000 blocks.

It is assumed that the initial capital will be recouped with 30% interest within the working life of the machine assuming a 60% utilisation i.e. in five years for the Cinva Ram and six years for the Brepack. This results in a discount factor of 2.436 for the Cinva Ram and 2.643 for the Brepack.

#### LABOUR COSTS

Labour per day for a Cinva Ram producing 300 blocks (1.4 MPa wet compressive strength) per 8 hour day

|              |   |
|--------------|---|
| soil winning | 2 men to dig the soil, spread it out for drying and crush/sieve the dried material. |
| soil winning | 1 man to mix the material and prepare batches for compaction.                       |

block                    2 men to operate the machine and stack the green  
pressing                blocks for curing.

Assuming the above labour distribution for a Cinva Ram production unit then the cost of labour per kg of soil used may be found.

|                                     |            |
|-------------------------------------|------------|
| Soil required per block (see data)  | 6.948 kg   |
| No of blocks produced per day       | 300        |
| Total mass of soil required         | 2,084.4 kg |
| Labour cost per man per day         | £3.50      |
| Labour required to win/process soil | 3 man days |
| Total soil winning labour cost      | £10.50     |
| Soil winning labour cost per kg     | £0.0050    |

|  |                   |
|--|-------------------|
| Labour cost for block pressing (Cinva Ram) | £0.0233 per block |
| Labour cost for block pressing (Brepack)   | £0.0282 per block |

#### CEMENT COST

|                          |        |
|--------------------------|--------|
| Cement cost per 50kg bag | £3.000 |
| Cement cost per kg       | £0.060 |

#### CINVA RAM DATA (prices in Pounds Sterling 1993)

Purchase cost of machine £382.88 (1988 cost reported by Webb (1988) inflated by 5% pa)  
Total freshly demoulded weight of one block 8.0kg (demould density 1980kg/m<sup>3</sup>, volume 290x140x100mm)

#### 1.4MPa wet compressive strength

|  |          |
|--|----------|
| Cement percentage required for 1.4MPa wet strength | 6.6%     |
| (based on figure 6.5a)                             |          |
| Mass of soil per block                             | 6.948 kg |
| Mass of cement per block                           | 0.459 kg |
| Mass of water per block                            | 0.593 kg |

#### 2.8MPa wet compressive strength

|  |          |
|--|----------|
| Cement percentage required for 2.8MPa wet strength | 11.7%    |
| (based on figure 6.5a)                             |          |
| Mass of soil per block                             | 6.631 kg |
| Mass of cement per block                           | 0.776 kg |
| Mass of water per block                            | 0.593 kg |

CINVA RAM ANALYSIS FOR 1.4MPa WET COMPRESSIVE STRENGTH

|   |                |
|---|----------------|
| Cost of cement per block                                  |                |
| 0.459 kg cement per block @ £0.060 per kg                 | £0.0275        |
| Cost of soil winning labour per block                     |                |
| 6.948 kg soil per block @ £0.0050 per kg                  | £0.0347        |
| Cost of soil pressing labour per block<br>(for Cinva Ram) | £0.0233        |
| Cost of machine depreciation per block                    |                |
| $£382.88 \div 2.436 \times 5 \div 270,000$                | <u>£0.0029</u> |
| Total cost per block                                      | £0.0884        |

CINVA RAM ANALYSIS FOR 2.8MPa WET COMPRESSIVE STRENGTH

|   |                |
|---|----------------|
| Cost of cement per block                                  |                |
| 0.776 kg cement per block @ £0.060 per kg                 | £0.0466        |
| Cost of soil winning labour per block                     |                |
| 6.631 kg soil per block @ £0.0050 per kg                  | £0.0332        |
| Cost of soil pressing labour per block<br>(for Cinva Ram) | £0.0233        |
| Cost of machine depreciation per block                    |                |
| $£382.88 \div 2.436 \times 5 \div 270,000$                | <u>£0.0029</u> |
| Total cost per block                                      | £0.1060        |

BREPACK DATA (prices in Pounds Sterling 1993)

Purchase cost of machine £3828.80 (1988 cost reported by Webb (1988) inflated by 5% pa)  
 Total freshly demoulded weight of one block 8.65kg (demould density 2130 kg/m<sup>3</sup>, volume 290x140x100mm)

1.4MPa wet compressive strength

Cement percentage required for 1.4MPa wet strength 4.3%  
 Mass of soil 7.679 kg  
 Mass of cement 0.330 kg  
 Mass of water 0.640 kg

2.8MPa wet compressive strength

Cement percentage required for 2.8MPa wet strength 7.6%  
 Mass of soil 7.444 kg  
 Mass of cement 0.566 kg  
 Mass of water 0.640 kg

BREPACK ANALYSIS FOR 1.4MPa WET COMPRESSIVE STRENGTH

|   |                |
|---|----------------|
| Cost of cement per block                                |                |
| 0.330 kg cement per block @ £0.060 per kg               | £0.0198        |
| Cost of soil winning labour per block                   |                |
| 7.679 kg soil per block @ £0.0050 per kg                | £0.0384        |
| Cost of soil pressing labour per block<br>(for Brepack) | £0.0282        |
| Cost of machine depreciation per block                  |                |
| $£3828.80 \div 2.643 \times 6 \div 270,000$             | <u>£0.0322</u> |
| Total cost per block                                    | £0.1180        |

BREPACK ANALYSIS FOR 2.8MPa WET COMPRESSIVE STRENGTH

|   |                |
|---|----------------|
| Cost of cement per block                                |                |
| 0.566 kg cement per block @ £0.060 per kg               | £0.0340        |
| Cost of soil winning labour per block                   |                |
| 7.444 kg soil per block @ £0.0050 per kg                | £0.0372        |
| Cost of soil pressing labour per block<br>(for Brepack) | £0.0282        |
| Cost of machine depreciation per block                  |                |
| $£3828.80 \div 2.643 \times 6 \div 270,000$             | <u>£0.0322</u> |
| Total cost per block                                    | £0.1316        |

The data given above is summarised in table 6.6 below. It can be seen from this simple analysis that for a final wet strength of 1.4 MPa and 2.8 MPa, high pressure compaction is 33.5% and 24.1% more expensive respectively.

The above model assumes a 30% interest rate and hence penalises the Brepack as a result of its higher capital cost. However this high capital cost is not the only penalty.

The Brepack compaction process must take longer than the Cinva Ram as an additional hydraulic circuit must be pressurised and hence the compaction cost in terms of operator labour is higher as the productivity is reduced.

**Table 6.6a** Block production cost comparison (Sri Lanka)

| Cost per Block                | wet strength<br>1.4 MPa     | wet strength<br>2.8 MPa     |
|-------------------------------|-----------------------------|-----------------------------|
| Cinva Ram<br>2 MPa compaction | £0.088                      | £0.106                      |
| Brepack<br>10 MPa compaction  | £0.118<br>+33.5% over 2 MPa | £0.132<br>+24.1% over 2 MPa |

Compaction at higher pressure produces denser blocks which use less cement but more soil. Hence the costs associated with the soil are increased. In the above model it was assumed that the soil would be available free of charge except for the labour cost involved in winning it. If a secondary cost must be paid for the soil, land rental or a purchase price, then the high pressure compaction route is further disadvantaged.

**Table 6.6b** Percentage breakdown of block costs (Sri Lanka).

| Cost Parameter       | Cinva Ram<br>1.4 MPa strength | Brepack<br>1.4 MPa strength | Cinva Ram<br>2.8 MPa strength | Brepack<br>2.8 MPa strength |
|----------------------|-------------------------------|-----------------------------|-------------------------------|-----------------------------|
| cement               | 31.1%                         | 16.6%                       | 44.0%                         | 25.8%                       |
| soil winning labour  | 39.2%                         | 32.4%                       | 31.3%                         | 28.3%                       |
| pressing labour      | 26.4%                         | 23.8%                       | 22.0%                         | 21.4%                       |
| machine depreciation | 3.3%                          | 27.2%                       | 2.7%                          | 24.5%                       |
| total                | 100%                          | 100%                        | 100%                          | 100%                        |

Table 6.6b shows the percentage cost breakdown for the four blocks produced. It can be seen that although the high pressure compaction machine does reduce the cement demand, both the machine depreciation and the labour costs counteract this benefit.

For these machines using this soil type, increasing the cement content appears to be more economic than increasing the compaction pressure. Even if the life of the high pressure machine is doubled high pressure compaction remains the more costly. However what is not clear from this analysis is the quality of the final blocks. Although both machines should produce blocks with the same wet compressive strength, their densities will be different. Ultimate bearing strength when wet is not the only valid measure of performance but the most expedient to test and numerically quantify. The blocks' durability may be different as a result of their differing

density. Work is currently under way at The University of Warwick to investigate this.

The above analysis is only valid for the cement and labour rates quoted for Sri Lanka. In other areas the relative cost of cement and labour may be completely different. For example in rural Zimbabwe the cost of cement is increased to £3.50 per 50kg bag while the wage rate is reduced to £0.80 per man per day. The effect of this shown in tables 6.6c and 6.6d

**Table 6.6c** Block production cost comparison (rural Zimbabwe)

| Cost per Block                | wet strength<br>1.4 MPa      | wet strength<br>2.8 MPa      |
|-------------------------------|------------------------------|------------------------------|
| Cirva Ram<br>2 MPa compaction | £0.0479                      | £0.0698                      |
| Brepack<br>10 MPa compaction  | £0.0701<br>+46.3% over 2 MPa | £0.0864<br>+23.8% over 2 MPa |

It can be seen that even for a rural environment, where the daily wage rate is much lower than the cost of a bag of cement, high pressure compaction remains the more expensive option. For this case it is primarily the machine depreciation cost which dominates the analysis as the labour costs are greatly reduced.

**Table 6.6d** percentage breakdown of block costs (Zimbabwe)

| Cost Parameter       | Cirva Ram<br>1.4 MPa strength | Brepack<br>1.4 MPa strength | Cirva Ram<br>2.8 MPa strength | Brepack<br>2.8 MPa strength |
|----------------------|-------------------------------|-----------------------------|-------------------------------|-----------------------------|
| cement               | 67.0%                         | 32.9%                       | 77.8%                         | 45.9%                       |
| soil winning labour  | 15.8%                         | 12.1%                       | 10.4%                         | 9.5%                        |
| pressing labour      | 11.1%                         | 9.1%                        | 7.6%                          | 7.3%                        |
| machine depreciation | 6.1%                          | 45.9%                       | 4.2%                          | 37.3%                       |
| total                | 100%                          | 100%                        | 100%                          | 100%                        |

If the cement cost were increased to £6.00 per 50kg bag while the labour cost remained at the Sri Lankan value of £3.50 per man per day then the high pressure compaction route still remains the more expensive although the margin of difference is reduced (table 6.6e) to 18.8% and 8.5% for 1.4 MPa and 2.8MPa strength standards respectively.

**Table 6.6e** Block production cost comparison (if £6.00 per 50 kg of cement in Sri Lanka)

| Cost per Block                | wet strength<br>1.4 MPa      | wet strength<br>2.8 MPa      |
|-------------------------------|------------------------------|------------------------------|
| Cinva Ram<br>2 MPa compaction | £0.1160                      | £0.1525                      |
| Brepack<br>10 MPa compaction  | £0.1378<br>+18.8% over 2 MPa | £0.1655<br>+ 8.5% over 2 MPa |

The above analysis is not able to cover differences in the production efficiency and adaptability. Compaction to high pressure produces blocks which have a higher freshly demoulded (green) strength as a result of their higher density. This reduces the risk of block breakage during ejection and transportation to the curing area which has been reported by Lawson (Lawson, 1992, Ref No.22) to be as high as 50% in some extreme cases.

Moreover, because of the increased green block density the range of soil which can be used for production is larger for the high pressure machines. Green strength depends on the soil particle grading and the block density. If the green block density is reduced then for the same green strength or handleability the soil's clay content must be increased. i.e. high pressure compaction allows the use of soils with lower clay contents than those acceptable for low pressure compaction.

In conclusion, in most situations low pressure compaction will be more economic than high pressure compaction, provided that the block breakage rate is acceptably low, i.e. a moderate to high<sup>5</sup> clay content soil is used. If the cost of high pressure machines can be significantly reduced, while keeping the production rate similar to that of the low pressure machines, then high pressure compaction may prove to be more economic. Moreover if high pressure compaction is found to increase block durability then a small cost premium may be acceptable.

---

<sup>5</sup> Moderate and high clay contents within the acceptable clay content bounds of 10 - 30%.

## APPENDICES

APPENDIX A: BIBLIOGRAPHY

APPENDIX B: *SOIL-A* PROFILE

APPENDIX C: EXPERIMENTAL METHOD

APPENDIX D: EXPERIMENTAL  
INSTRUMENTATION



## APPENDIX A BIBLIOGRAPHY

1. Agarwal, A.: Mud, mud. The potential of earth-based materials for Third World housing. (London, International Institute for Environment and Development, 1981).
2. British Standards Institution: Methods of testing soils for civil engineering purposes, doc. BS1377 (London, BSI, 1991).
3. British Standard Institution: Methods of test for stabilised soil, doc. BS1924 (London, BSI, 1975).
4. Building Research Establishment.: Building in hot climates, A Selection of Overseas Building Notes. (London, H.M.S.O., 1980).
5. Carter, M. & Bentley, S.P.: Correlations of Soil Properties. (London, Pentech Press, 1991).
6. Craig, R.F.: Soil Mechanics, fourth ed. (Wokingham, Van Nostrand Rheinhold (UK) Co Ltd, 1987).
7. Das, B.M.: Fundamentals of Soil Dynamics. (New York, Elsevier Science Publishing Co, 1983).
8. Doat, P. et al. Construire en Terre. (Paris, CRATerre, 1979).
9. Handbook For Building Homes of Earth. Department of Housing and Urban Development, Office of International Affairs, Washington, D.C. 20410 (undated).
10. Ingles, O.G. & Metcalf, J.B.: Soil Stabilization Principles and Practice (London, Butterworths, 1972).
11. The Institution of Civil Engineers.: Ground Treatment by Deep Compaction. (London, ICE, 1976).
12. International Labour Office.: Small-scale Manufacture of Stabilised Soil Blocks. (Geneva, Switzerland, Technology Series, Technical Memorandum No.12, ILO Publications 1987).
13. Norton, J.: Building With Earth: A Handbook. (London, Intermediate Technology Publications Ltd, 1986).
14. O'Reilly, M.P. & Brown, S.F.: Cyclic Loading of Soils: from theory to design. (London, Blackie, 1991).
15. Spence, R.J.S. & Cook, D.J.: Building Materials in Developing Countries. (Chichester, Wiley, 1983).

16. Stulz, R.: Appropriate Building Materials, (London, U.K / SKAT. St.Gallen, Switzerland, Intermediate Technology Publications Ltd, 1983).
17. United Nations.: Soil-Cement its Use in Building, (United Nations Publication, Sales No.: 64.IV.6, 1964)
18. Volunteers in Technical Assistance: Making building blocks with the CINVA-RAM block press. (Mt. Rainier, Maryland, VITA, 1977).
19. Webb, D.J.T.: Stabilised Soil Building Blocks. (University of Newcastle-upon-Tyne, Ph.D. Thesis, 1988).
20. Webb, D.J.T.: The work of the Building Research Establishment, on lime stabilised soil blocks for Third World housing. (Paper presented at the First International Seminar on Lime and Other Alternative Cements, 9-11 December 1991, Stoneleigh, UK, held by the Intermediate Technology Development Group, Rugby, UK, 1991).
21. Williams, F.H.P. & Maclean, D.J.: The Compaction of Soil. A Study of the Performance of Plant, Road Research Technical Paper No. 17. (London, H.M.S.O., 1950).
22. Lawson, W. Personal communication. (1992).

## APPENDIX B SOIL-A DETAILS

Soil-A is an artificial soil produced at the University of Warwick by blending building sand with grade E kaoline powder. This soil was used for all experimentation to aid repeatability and allow a consistent soil composition throughout the course of the current research work. The soil was blended such that it fell within the ideal specification for soil-cement given by United Nations (1964, Ref No.17). This states that the optimum soil composition is; 75% sand, 25% silt and clay, of which more than 10% is clay.

Building Sand:

|          |      |       |
|----------|------|-------|
| Grading: | Sand | 84.2% |
|          | Silt | 8.8%  |
|          | Clay | 7.0%  |

Grading curve:

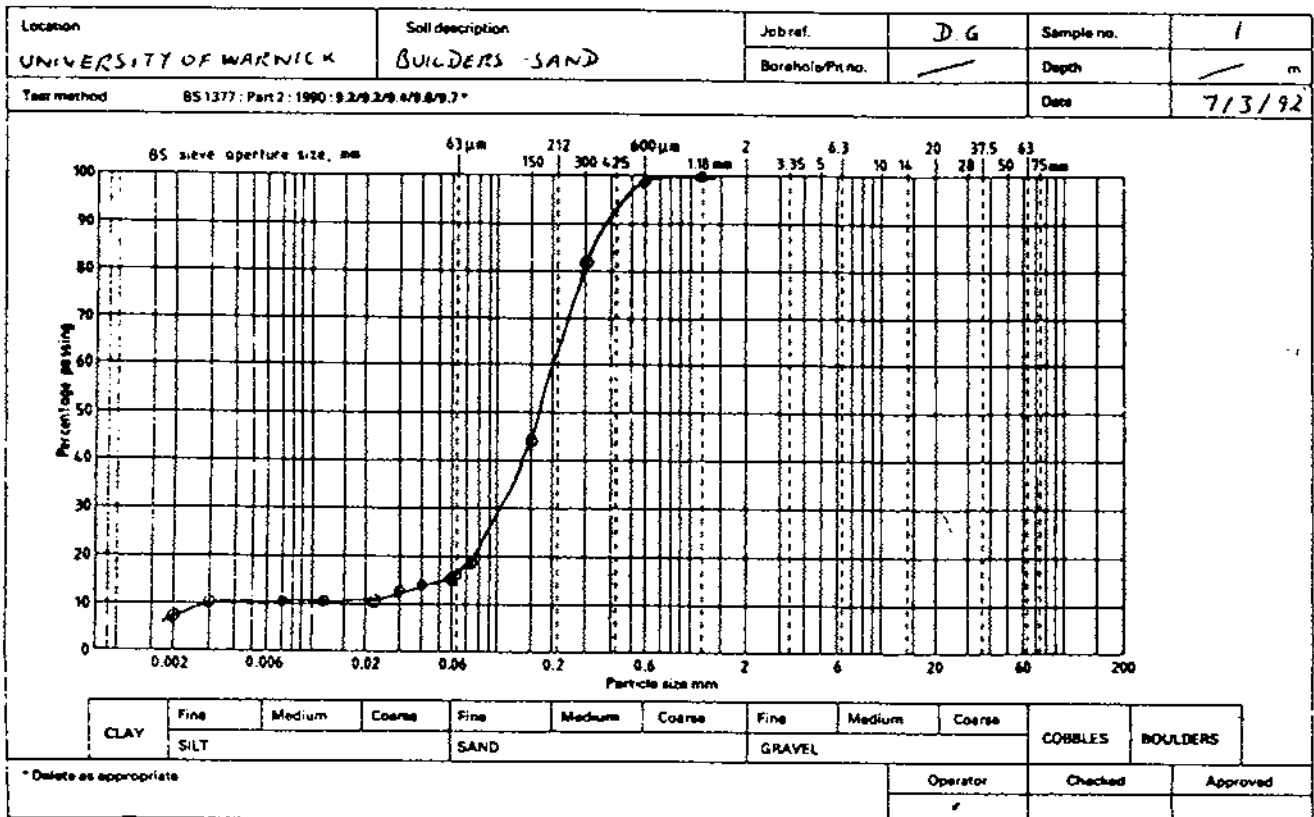

Kaoline Grade E powder:

|                                |                       |
|--------------------------------|-----------------------|
| Specific gravity               | 2.6                   |
| Specific Surface Area          | 8.0 M <sup>2</sup> /g |
| Water soluble salts            | 0.15 %                |
| SiO <sub>2</sub>               | 50 %                  |
| Al <sub>2</sub> O <sub>3</sub> | 35 %                  |
| Ph                             | 5 ± 0.5               |

|                         |               |         |          |
|-------------------------|---------------|---------|----------|
| Soil-A mix proportions: | Building Sand | 9 parts | (7.2 kg) |
|                         | Kaoline       | 1 parts | (0.8 kg) |

|                |       |      |
|----------------|-------|------|
| Soil-A grading | 76.5% | Sand |
|                | 8.0%  | Silt |
|                | 15.5% | Clay |

Soil-A grading curve:

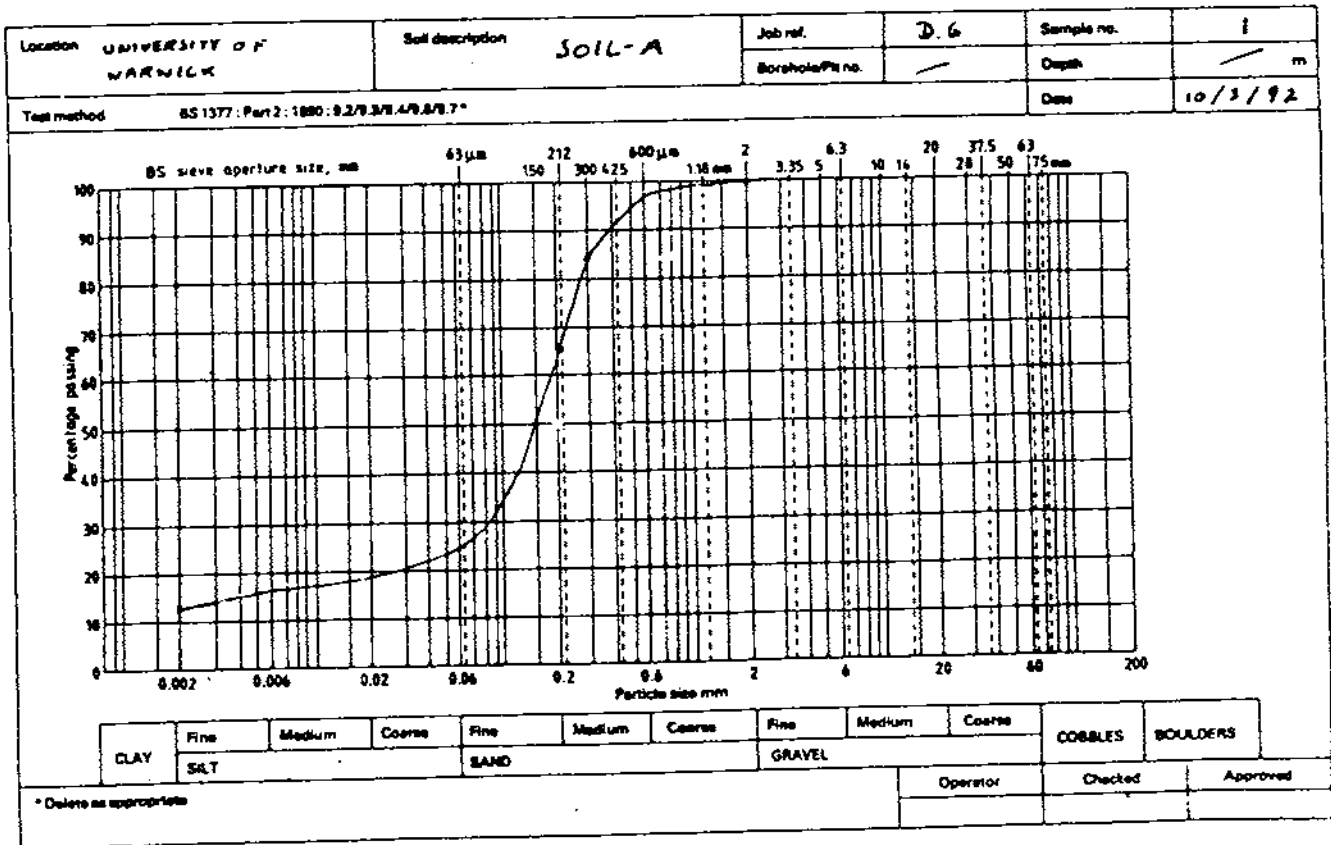

## APPENDIX C : EXPERIMENTAL METHOD

### UNSTABILISED BLOCK PRODUCTION (290X140X100mm)

For each block a batch of Soil-A was manufactured and mixed for 5 minutes with distilled water to give a moisture content of 4% (for batch proportions see below). This batch was then left overnight to homogenise before remixing to 8% moisture content. All batch proportions were weighed to  $\pm 0.05\text{g}$ . All mixing was mechanical, using a large Hobart soil mixer.

The material to fill the mould was weighed out as three equal quantities into three plastic bags and sealed.

After oiling the mould with a release agent (engine oil), the soil was placed in the mould. The contents of each bag was lightly tamped before adding the next. The mould top was then placed on the soil and its height above the compression machine bed measured and recorded. A dial gauge was then positioned such that the block height during compaction could be measured.

The block was then compressed in 5 tonne force increments up to 40 tonnes. After each force increment the applied force was held constant long enough for the block height and both LVDT readings to stabilise and be recorded (typically 1 minute). The block was then decompressed in a similar manner.

The compressed block was ejected from the mould by pressing the mould walls down over the lower piston. The green block was then transferred to a wooden base plate and its final dimensions recorded.

### UNSTABILISED MIX PROPORTIONS

7.200kg builders sand (0.5% moisture content)  
0.800kg kaoline grade E powder (0.7% moisture content)  
0.277kg distilled water (for 4% homogenisation)  
0.318kg distilled water (8% moisture content for compaction)

Mass of 8% moisture content soil-A for block compaction  
8.532kg

### STABILISED BLOCK PRODUCTION (290X140X100mm)

For stabilised block production the above method was used but after homogenisation at 4% moisture content, 0.398kg of cement and 0.350kg of distilled water were added.

On ejection from the mould the green blocks were transferred

to a plastic bag containing a damp tissue and sealed. The blocks were then left to cure for six days before immersion in water for the final 24 hours. Curing temperature was 22-24°C. After seven days the blocks were tested for wet compressive strength. Both the upper and lower block faces were capped with fibre board before compressive strength testing in a Denison concrete testing machine.

#### STABILISED SOIL-CEMENT CYLINDERS ( $\phi$ 50mm, height 100mm)

The method given below is a copy of that used during manufacture. Six days after compaction each sample was soaked for 24 hours. On the seventh day after compaction the samples were capped with fibre board and tested for compressive strength in a Denison concrete testing machine. Although the Denison machine was operating below its range of grade 1 calibration ( $\pm 1$  %) it had been recently recalibrated by an authorised testing house who indicated that the largest error given by the machine would be  $\pm 3$  % of the recorded value.

1. Measure out all ingredients for required batch. The water should be weighed into a pre-wetted container to allow for the quantity which remains in the container.

2. Place the 4% homogenised soil in the mixer. Sprinkle the cement onto the soil and note the time. Mix for 2 to 3 minutes or until the mixture looks uniform in colour, place a large plastic bag around the top of the mixer's bowl to reduce the evaporation of the water. Sprinkle in the weighed water, try not to pour the water onto the sides or the mixing paddle. Mix for a further 3 to 4 minutes or at least until the mixture looks uniform.

3. Weigh out 453.6g of the mixture, leaving the mixing bowl covered with a large plastic bag to reduce the moisture loss.

4. Oil the mould with the release oil and assemble for filling. Place approx one third of the mixture into the mould using the paper funnel. Take care not to spill any soil. Tamp the soil down with the steel bar. Repeat this for the next two thirds of the mix. Place the mould piston on top and try to centralise the main body between the end pistons.

5. Place the mould, red ring down, in the centre of the compression machine plated and compress to the required force twice (forces listed below).

6. Lift off the compression machine. Remove top and bottom pistons. Place the ejection ram in the base and the collars on top of the mould. Lower the compression machine to eject the sample. If you try and rotate the mould while compressing, it will be apparent when the sample has been ejected far enough for final removal by hand. Note the time that the sample was ejected.

7. Write the identification number on the top face and place it into a plastic bag. Repeat the above for the next two cylinders and then weigh and measure the length of each. Finally place them inside a plastic bag with one moist tissue and seal the bag.

Compaction forces:

|        |            |             |              |
|--------|------------|-------------|--------------|
| 1 MPa  | = 1.960 kN | use 2.0 kN  | (1.018 MPa)  |
| 2 MPa  | = 3.93 kN  | use 4.0 kN  | (2.037 MPa)  |
| 4 MPa  | = 7.85 kN  | use 8.0 kN  | (4.074 MPa)  |
| 6 MPa  | = 11.78 kN | use 12.0 kN | (6.112 MPa)  |
| 8 MPa  | = 15.71 kN | use 16.0 kN | (8.149 MPa)  |
| 10 MPa | = 19.63 kN | use 20.0 kN | (10.186 MPa) |

ORDER:

Start with 10 MPa compression and 11% cement. Follow with 10 MPa 9% etc. This should minimise confusion with the compression machine!

BATCH PROPORTIONS:

All cylinders are to be compacted at eight percent water content and a dry mass of soil + cement of 420g, giving a fill mass per cylinder of 453.6g .

The figures below relate to batch mass measures. Each batch should contain enough material to make 3 cylinders with some material left over, approx 225g.

It is important to remember to note the time when the cement is added to the 4% moisture content soil.

BATCH TO MIX UP AND STAND OVERNIGHT:

(measure all mass to  $\pm 0.05g$ )

|         |                 |
|---------|-----------------|
| 9kg     | lab-dry soil    |
| 1kg     | kaolin from bag |
| 0.347kg | distilled water |

3% CEMENT BATCH:

|         |                     |
|---------|---------------------|
| 1484.4g | 4% homogenised soil |
| 42.7g   | cement              |
| 60.6g   | distilled water     |

5% CEMENT BATCH:

|         |                     |
|---------|---------------------|
| 1456.0g | 4% homogenised soil |
| 70g     | cement              |
| 61.7g   | distilled water     |

7% CEMENT BATCH:

|         |                     |
|---------|---------------------|
| 1428.7g | 4% homogenised soil |
| 96.3g   | cement              |
| 62.7g   | distilled water     |

9% CEMENT BATCH:

|         |                     |
|---------|---------------------|
| 1402.5g | 4% homogenised soil |
| 121.5g  | cement              |
| 63.8g   | distilled water     |

11% CEMENT BATCH:

|         |                     |
|---------|---------------------|
| 1377.3g | 4% homogenised soil |
| 145.6g  | cement              |
| 64.8g   | distilled water     |



## APPENDIX D : EXPERIMENTAL INSTRUMENTATION

### THE LVDT TRANSDUCER

The LVDT transducer (see figures D1, D2 and D3) was designed to flush-mount in the mould walls. The main body of the transducer is machined from EN24T steel to form a circular spring. The thickness and shape of the spring are such that it will remain well inside the elastic region of the steel such that deflection is proportional to the applied load. The spring is deflected by a cylindrical piston mounted in a tubular guide. Both the outer faces of the tubular guide and of the cylindrical piston are flush with the spring body face and mould wall under conditions of no load.

The LVDT plunger is screwed into the rear spring boss. The LVDT body is clamped inside the transducer by the olive ring. Any deflection of the spring is sensed by the LVDT and converted into a voltage signal. The voltage output from the LVDT is fed into a conditioner and finally displayed on a digital voltmeter. The LVDT transducers and conditioners are both made by Schlumberger Industries and were supplied by RS Components Ltd, catalogue No 646-527 and No. 646-599 respectively. The Schlumberger Part numbers are LVDT SM1 and type OD3 911040 transducer conditioner.

Initially quite large hysteresis was observed on unloading. This was found to be caused by an air lock between the piston and the spring body. The design was subsequently modified by including a 1.5mm diameter vent hole. Two such transducers were manufactured and used during the experimentation.

Figures D4 and D5 show the calibration plots for transducer No.1 and No.2 respectively. Minor machining differences led to each unit having a different spring constant and hence a different gain. The gain of each unit was found to be constant over time and constant within normal laboratory temperatures. The zero offset was found to vary with time, typically 1mV per 30 minutes. The zero load voltage was recorded immediately before each experiment so that the zero offset could be determined, this offset was assumed to remain constant for the duration of each test (20 minutes): The transducers' hysteresis lead to a 0.1MPa over reading after four full cycles.

The pressure transmitted to the mould wall was found by entering the recorded voltage into the transducer equation:

$$y = mx + c$$

where  $y$  = transmitted pressure /MPa

$m$  = transducer gain (found from calibration curves) /MPa/mV

$x$  = recorded voltage /mV

$c$  = zero offset correction (found by  $c = -mx$  at zero load)

Figure D6 shows the possible locations for the transducers in the mould side wall.

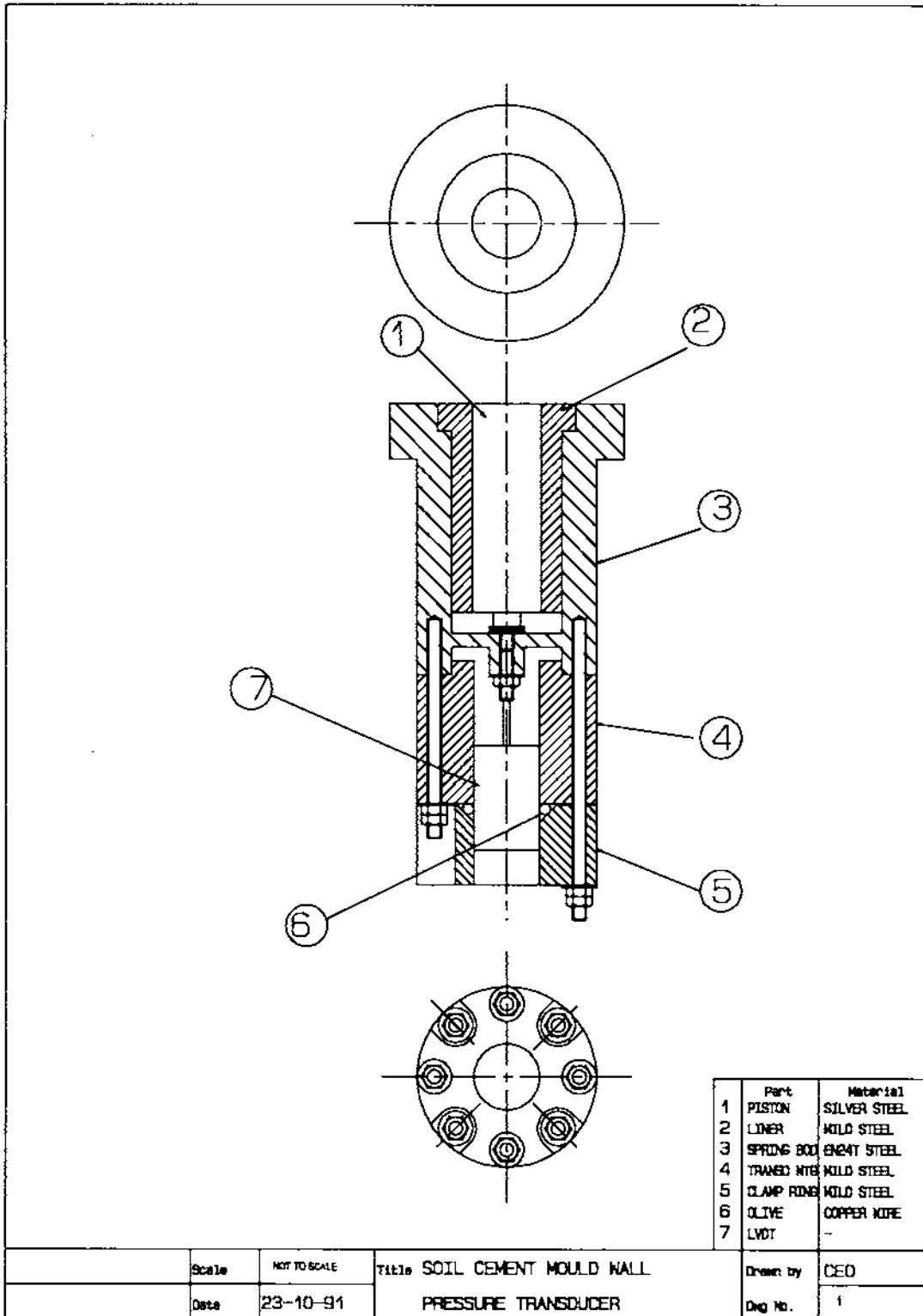
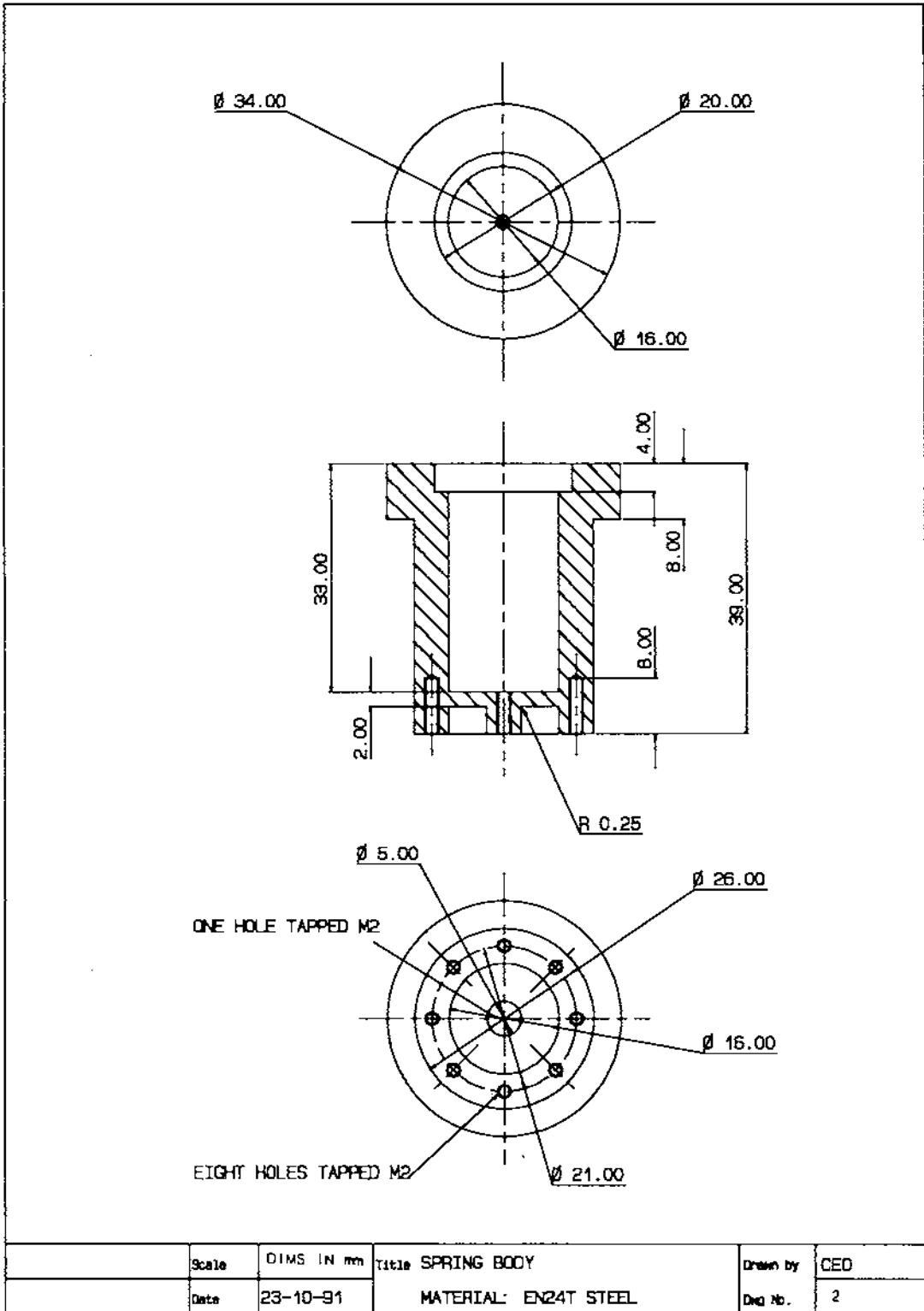

Figure D1 LVDT Transducer Assembly Drawing



**Figure D2** LVDT Transducer Spring Body

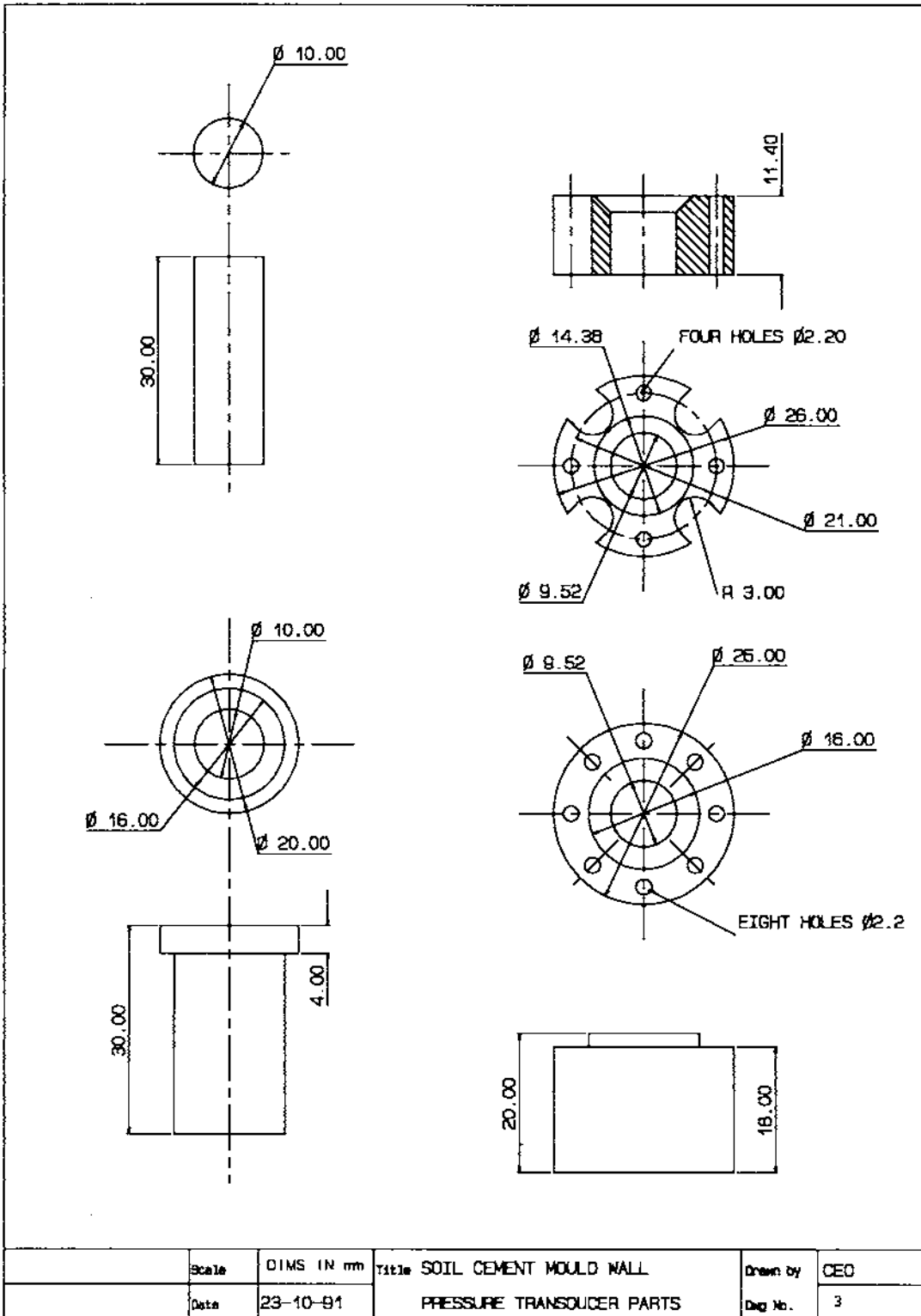

Figure D3 LVDT Transducer Parts

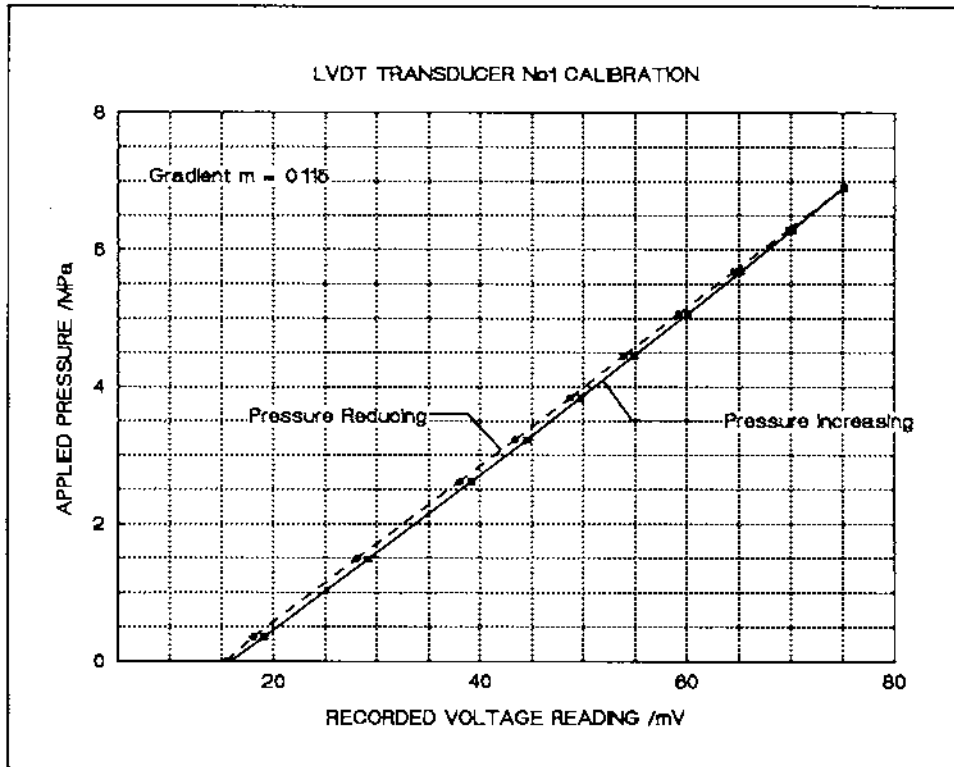

Figure D4 Calibration of LVDT transducer No.1

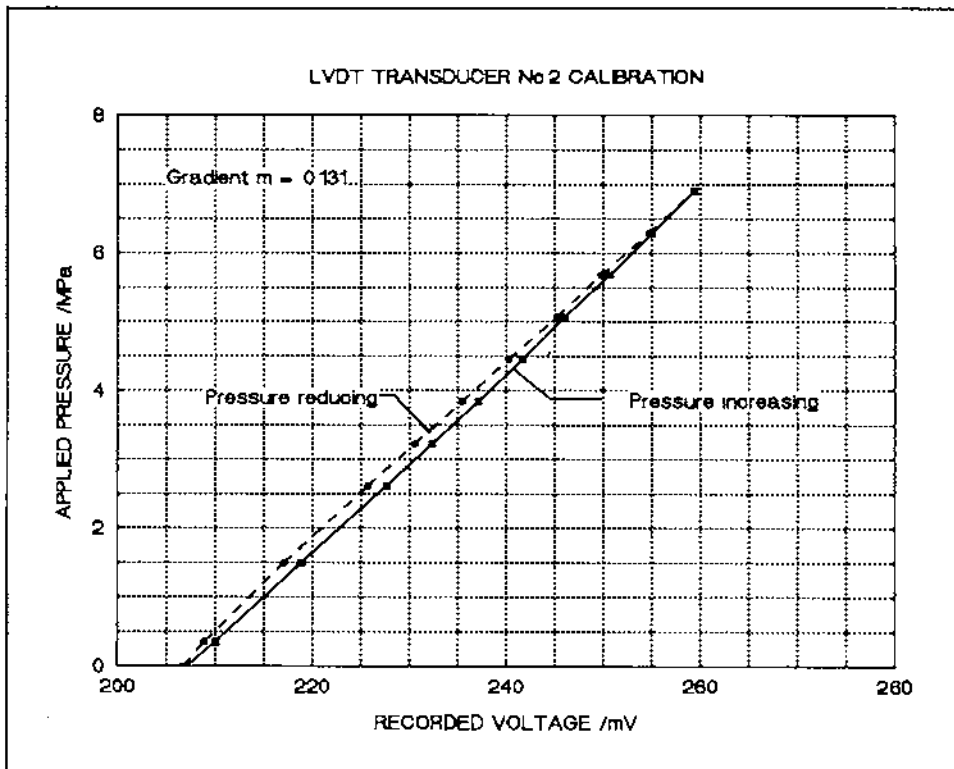

Figure D5 Calibration of LVDT transducer No.2

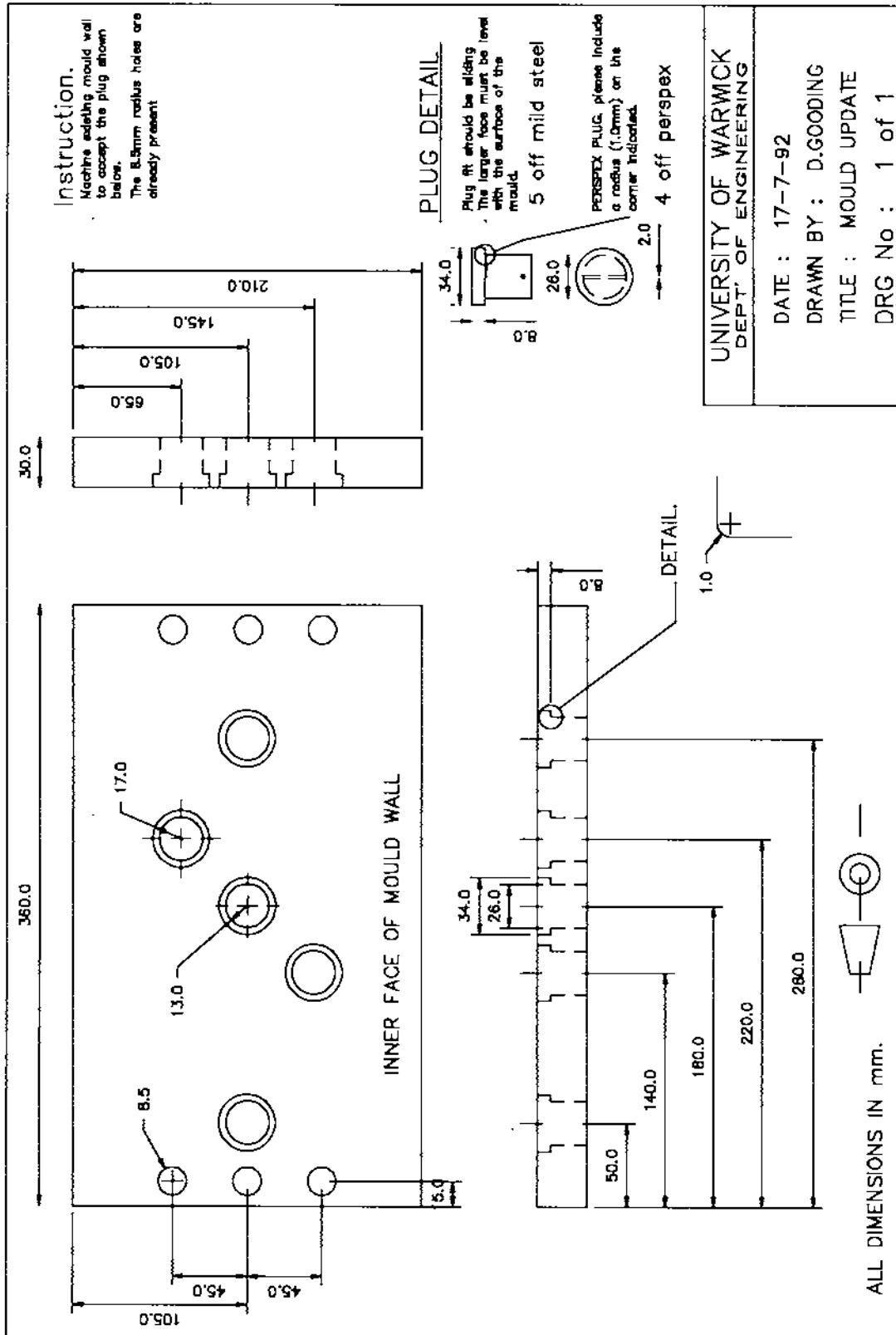

Figure D6 Transducer location sites in mould side wall

Testing Machine Details:

All wet compressive strength tests were made on a Denison Concrete test machine 7229/T91081, max load 100kN. Certified to grade 1 calibration at time of testing.

All soil-cement cylinders were compacted on a Monsanto Tensometer Type E (No. N120-79) with a 25kN load cell (No. 263). Certified to grade 1 calibration at time of testing.

All soil-cement blocks were compacted on an Amsler compression machine (No. ES1120), max load 40 tonnes. Certified to grade 1 calibration at time of testing.